

Data sheet

Compressor
for suction vehicles



VacuStar L 400

Compressor

- Overview page 2
- Dimensions page 4
- Features page 3
- Technical data page 4

VacuStar L 400

Compressor

■ Overview



CVS develops and manufactures compressor vacuum pumps and compressors specifically designed for installation in vacuum trucks. The development is made in close collaboration with our customers. This guarantees the optimum product for your application.

The compressor

The air cooled series L was developed especially for the high requirements for unloading suction vehicles.

Contact person



Roger Homberger

Head of Sales

+49 (0) 7623 71 741-24

+49 (0) 151 72 13 01 81

roger.homberger@cvS-eng.de



Patrick Zettler

Sales

+49 (0) 7623 71 741-23

+49 (0) 162 25 25 694

patrick.zettler@cvS-eng.de



Helen Kreissl

Internal Sales

+49 (0) 7623 71 741-21

helen.kreissl@cvS-eng.de

■ Features

- High quality compressors from CVS for reliable discharge
- Durable and robust design guarantee long lasting performance and high operating hours
- Compact and light-weight compressors for higher payload on the truck

Compressors with system

The series L delivers a volume flow from 225 up to 345 m³/h / 130 – 203 cfm.

The compressor is lubricated automatically by an integrated oil pump.

Technical subject to alteration



■ Advantages

- Connectivity for hydraulic motor
- Optimized cooling
- Low weight
- Visual oil level indicator
- Shaft end exposed for driving using V-belts, cardan shaft and flexible coupling



■ Dimensions

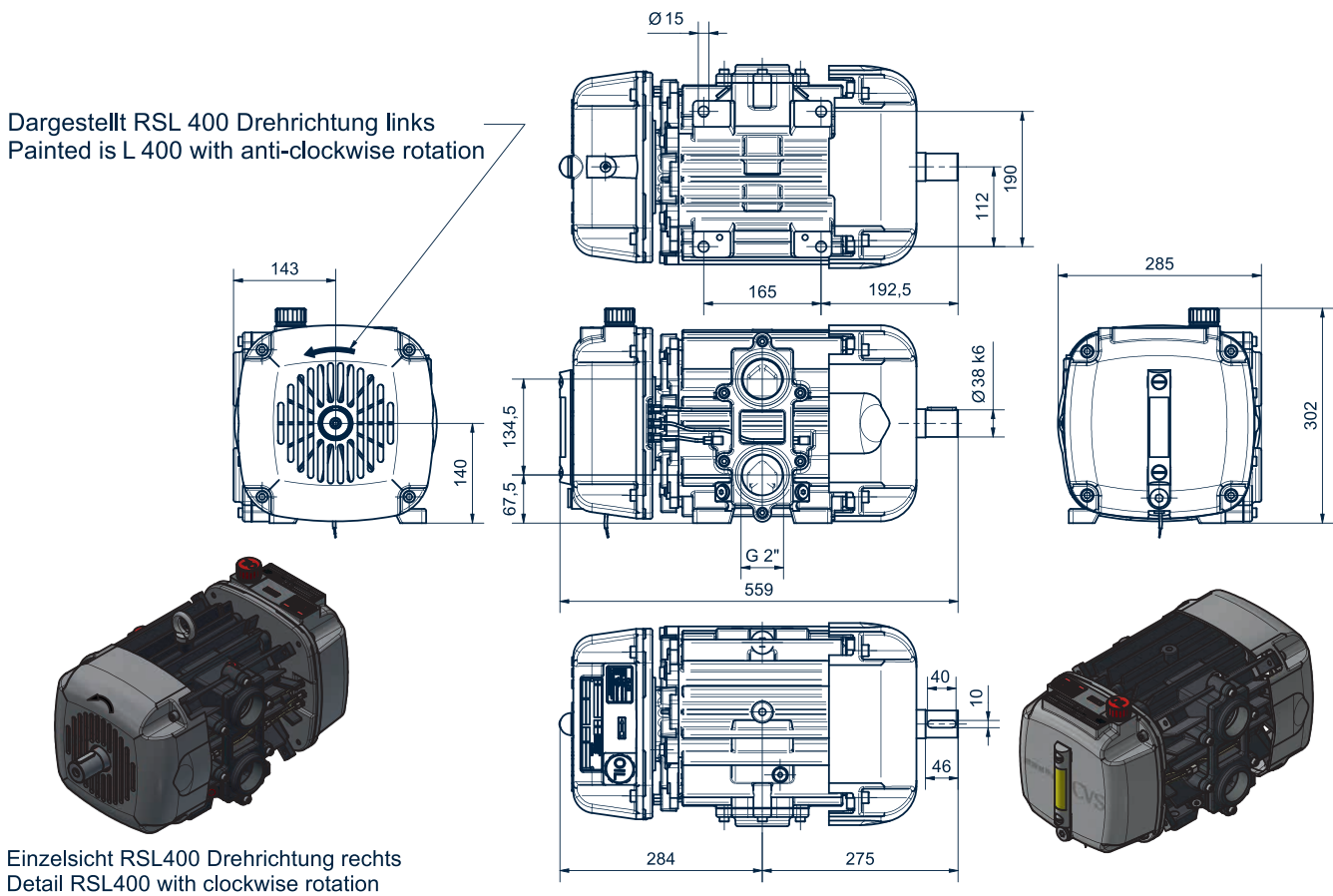

■ Technical data

		VacuStar L 400
Suction volume flow at free air	m³/h / cfm	345 / 203
Volume flow at 2 bar g / 29 psig	m³/h / cfm	305 / 179
Max. operating pressure	bar g / psig	2.0 / 29.0
Nominal speed	1/min / rpm	1500
Power requirement at 2 bar / 29 psi	kW / hp	19 / 25.5
Weight	kg / lb	79 / 174

Technical subject to alteration