

Operating instructions

**Screw compressor
SKL 1200 C**



Doc-ID: 5112 / BA / EN

Release: Rev. 02 / 28/03/2023

The operating instructions must be read by the SKL 1200 C operator before start-up!

Translation of the original operating manual

© CVS engineering GmbH

Großmattstraße 14
79618 Rheinfeldern / Germany

Phone: +49 (0)7623 71741-0
Customer service: +49 (0)7623 71741-0
E-Mail: info@cvs-eng.de
Internet: www.cvs-eng.de



1	General	4
1.1	Information regarding the operating instructions	4
1.2	Pictogram explanation	5
1.3	Limitation of Liability	6
1.4	Copyright protection.....	6
1.5	Spare parts	7
1.6	Warranty conditions	7
1.7	Customer Service	7
2	Safety	8
2.1	Intended use	8
2.2	Acceptance and monitoring	8
2.3	Operator's responsibility	8
2.4	Operating personnel	9
2.4.1	Requirements	9
2.5	Personal protective equipment	10
2.6	Occupational safety and special risks	10
3	Technical data	15
4	Design and function	17
4.1	Design.....	17
4.2	Function	18
4.3	Control and display elements	18
5	Transport and storage	19
5.1	Safety notes for transport	19
5.2	Transport.....	19
5.3	Storage	20
6	Start-up and operation	21
6.1	Safety during start-up	21
6.2	Start-up	21
6.3	Switching off.....	22
6.4	Inspections to be performed	22
7	Maintenance	22
7.1	Safety during maintenance work	22
7.2	Maintenance schedule.....	23
7.3	Performance of maintenance work.....	24
8	Malfunctions	27
8.1	Safety.....	27
8.2	Recommissioning after corrective action.....	27
8.3	Malfunction table.....	28
9	Spare parts	30
10	Decommissioning and disposal	31
	Index	32

General

1 General

1.1 Information regarding the operating instructions

These operating instructions provide important information on handling the SKL 1200 C screw compressor, hereinafter referred to as the "compressor". A precondition for safe operation is the observance of all specified safety and handling instructions.

Furthermore, all local accident prevention regulations and general safety regulations valid for the application area of the compressor must be observed.

Carefully read the operating instructions before starting any work! It is a product component and must be kept in direct proximity of the compressor, well accessible to the personnel at all times.

The operating instructions are limited exclusively to the use by trained specialists.

When passing the compressor on to third parties, the operating instructions must also be handed over.

These operating instructions do not apply to the operation of a compressor unit completed by a third party.

1.2 Pictogram explanation

Warning notes

Warning notes are characterised by pictograms in these operating instructions. The warning notes are marked by signal words expressing the extent of the hazard.

It is absolutely essential to observe the notes and to proceed with caution in order to prevent accidents as well as bodily injuries and property damage.



DANGER!

points to an immediately dangerous situation, which can lead to death or serious injuries if it is not avoided.



WARNING!

... points to an immediately dangerous situation, which can lead to death or serious injuries if it is not avoided.



CAUTION!

... points to a potentially dangerous situation, which can lead to minor or light injuries if it is not avoided.



ATTENTION!

... points to a potentially dangerous situation, which may lead to property damage if it is not avoided.

Hints and recommendations



NOTE!

... highlights useful hints and recommendations as well as information for an efficient and trouble-free operation.

General

1.3 Limitation of Liability

All specifications and notes in these operating instructions were compiled with consideration to the valid standards and regulations, the state of the art as well as to our long-standing knowledge and experience.

The manufacturer is not liable for damages caused by:

- Non-observance of the operating instructions
- Improper use
- Deployment of non-trained personnel
- Arbitrary modifications
- Technical changes
- Use of non-approved spare and wear parts

The actual scope of supply may differ from the explanations and illustrations described in this manual in case of special designs, if additional order options are made use of, or due to latest technical changes.

Incidentally, the responsibilities agreed upon in the delivery contract, the general terms and conditions as well as the manufacturer's conditions of delivery and the statutory provisions valid at the time of contract conclusion shall apply.

Warranty

The manufacturer guarantees the correct functioning of the applied process technology and the performance parameters identified.

The warranty period commences on the date the compressor is delivered to the customer.

Components are exempted from the warranty and from claims for defects as far as wear and tear damage is concerned.

1.4 Copyright protection

Surrendering the operating instructions to third parties without written permission of the manufacturer is not permitted.



NOTE!

Content details, texts, drawings, pictures and other illustrations are protected by copyright and are subject to industrial property rights. Any improper use shall be liable to prosecution.

Any type and form of duplication, also of extracts, as well as the exploitation and/or communication of the contents are not permitted without the manufacturer's written declaration of consent.

1.5 Spare parts

**WARNING!****Risk of injury by incorrect spare parts!**

Incorrect or defective spare parts can result in damage, malfunctions or total failure and also impair safety.

Therefore:

- Use only the manufacturer's original spare parts.

Procure spare parts from authorised dealers or directly from the manufacturer. Refer to page 2 for address.

1.6 Warranty conditions

For warranty conditions refer to the "General Terms and Conditions".

1.7 Customer Service

Our customer service can be contacted for any technical advice. Information about the responsible contact person can be retrieved by telephone, fax, E-mail or via the Internet at any time, refer to manufacturer's address on page 2.

Safety

2 Safety

2.1 Intended use

The screw compressor SKL 1200 C is intended for the installation in a superordinate system.

The compressor SKL 1200 C is intended exclusively for the compression of filtered air.

Use the compressor only as intended.

All specifications in the operating instructions must be strictly adhered to (technical data, operating data, permissible working range, refer to chapter 3 in this regard).

All types of claims due to damage arising from improper use are excluded. The operator alone shall be responsible for any damage arising from improper use.

2.2 Acceptance and monitoring

The compressor is not subject to any acceptance and monitoring obligation.

2.3 Operator's responsibility

The compressor is used for industrial purposes.

The operator of the compressor is therefore subject to the legal obligations concerning occupational safety.

The provisions valid at the place of installation as well as the safety and accident prevention regulations of the Institution for statutory accident insurance and prevention must be observed. The operator must in particular:

- inform himself on the valid industrial safety regulations.
- determine the additional hazards that arise from the special working conditions at the compressor's place of installation by means of a hazard assessment.
- implement the necessary rules of conduct for operation of the compressor at the place of installation by means of user instructions.
- check at regular intervals during the compressor's entire period of use whether the user instructions correspond to the current state of the body of rules and regulations.
- adapt the operation instructions, if necessary, to the new regulations, standards, and operating conditions.
- clearly regulate the responsibilities for installing, operating, maintaining and cleaning the compressor.
- ensure that all employees working on or with the compressor have read and understood the operating instructions. In addition

he must at regular intervals train the employees in how to deal with the compressor and inform them about potential hazards.

In addition, it is the operator's responsibility to ensure that:

- is always in a technically perfect condition.
- is maintained in accordance with specified maintenance intervals.
- all safety equipment is regularly checked for completeness and correct functioning.

2.4 Operating personnel

2.4.1 Requirements



WARNING!
Risk of injury in case of inadequate qualification!

Improper handling can lead to considerable bodily injuries and property damage.

Therefore:

- Have any activities only carried out by the individuals designated for that purpose.

The operating instructions specify the following qualification requirements for the different fields of activity:

- **Instructed persons**
 have been instructed during instructions provided by the operator with regard to the work assigned to them and possible hazards arising from improper conduct.
- **Specialists**
 are due to their technical training, knowledge and experience and their knowledge of the pertinent regulations able to carry out the work assigned to them and to independently recognize potential hazards.

Safety

2.5 Personal protective equipment

When handling the compressor, it is necessary to wear personal protective equipment, in order to minimise health hazards.

- Before carrying out any work, properly don the necessary protective equipment such as gloves, safety goggles, etc. and wear during work.

2.6 Occupational safety and special risks

Depending on the installation situation, the compressor and/or the components may be marked with additional danger pictograms.

These pictograms can be for example:



DANGER!
General danger pictogram!

... denotes general dangerous situations for individuals. Non-observance of the safety instructions can result in severe injuries or death. .



DANGER!
Danger of burns!

... denotes the presence of a hot surface.



DANGER!
Rotating parts!

... marks that potentially hazardous rotating parts are present.

These safety instructions and the warning notes in the other chapters of this instructions must be observed in order to reduce health hazards and to avoid dangerous situations.

Hazard notes and occupational safety

For your own safety and that of the machine, the following information must be observed and complied with:

Improper operation

DANGER!
Danger due to improper operation!

- Only use the compressor in a perfect technical condition. Malfunctions that are relevant for safety have to be promptly eliminated.
- Conversions of the compressor are not permissible and can impair safety.
- Before carrying out regular maintenance, cleaning and repair work, switch off power supply and secure compressor against restarting (switch off drives).
- Never bridge any safety equipment or put it out of operation.
- Any work on the compressor and/or on electrical equipment must be carried out by specialised staff.
- Repair and maintenance work may only be carried out when the compressor is stationary. For this, the compressor must be secured against restarting!
- The compressor may not be under pressure or in a state of vacuum while work is being carried out on it.
Close shut-off valve on the vehicle side and vent the pipe between compressor and shut-off valve or manually relieve excess pressure at safety valve. Observe pressure gauge!
- The drive's protective equipment may only be removed when the compressor is stationary and has to be correctly refitted after completion of work.
- Only dismantle accidental contact protection after compressed air system and pressure pipe have cooled down.
- It is an environmental protection requirement that any liquids arising during maintenance work (e.g. oil) must be collected and disposed of in an environmentally compatible manner.

Safety

Moving components

**WARNING!****Risk of injury by moving components!**

Powered rotating components can cause the most serious injuries!

Therefore during operation:

- It is absolutely forbidden for persons to stay in the hazard area or in the immediate vicinity!
- Do not put safety devices and/or functions out of operation and do not render them inoperative or bypass them.
- Never reach into open outlets and inlets or into running equipment.

Before entering the hazard area:

- Switch off power supply and secure against restarting.
- Wait for standstill of lagging components.
- Wait for automatic dissipation and/or discharge of residual energies (compressed air).

Compressed air

**WARNING!****Risk of injury due to compressed air!**

Pneumatic energies can cause the most serious injuries.

In the case of damage to individual components, air can be discharged under high pressure and injure e.g. the eyes. Therefore:

- Before starting any work, first depressurise pressurised components. Pay attention to accumulators. Accumulator pressure must also be completely relieved.

Signposting

**WARNING!****Risk of injury by illegible pictograms!**

Labels and signs can become dirty or unrecognisable in the course of time.

Therefore:

- Always keep safety, warning and operating instructions in a well legible condition.
- Immediately replace damaged or obliterated signs or labels.

Improper transport

Danger!
Danger by falling down or tilting of the compressor!

The weight of the compressor may injure a person and cause serious bruising!

Therefore:

- Depending on the dead weight and size of the compressor, use a pallet on which the compressor can be moved by means of a fork lift.
- For lifting the compressor, use suitable lifting gear (slings etc.) that is designed for the weight of the compressor.
- When putting the slings in position, take care to avoid putting stress on individual components.
- Only use the provided attachment points with eye bolts.

Start-up, operation

WARNING!
Risk of injury due to improper start-up and operation

Improper start-up and operation can lead to serious bodily injuries or property damage. Therefore:

- Have all work during initial operation exclusively performed by the manufacturer's employees or by his authorised representatives or by trained personnel.
- Start-up and operation may only be performed by adequately qualified personnel that has been authorised and instructed by the operator.
- Before the start of any work, ensure that all covers and protective devices are correctly installed and function correctly.
- Never override any protective equipment during operation.
- Pay attention to tidiness and cleanliness in the working area! Loosely stacked or scattered components and tools are accident sources.

Safety**Maintenance and troubleshooting****WARNING!****Risk of injury due to improper maintenance and troubleshooting!**

Improper maintenance and troubleshooting can lead to serious bodily injuries or property damage. Therefore:

- Maintenance work and troubleshooting work may only be carried out by sufficiently qualified and instructed personnel.
- Secure the compressor against restarting, switch off drives!
- Before starting any work, provide for sufficient space and freedom of movement during assembly.
- Pay attention to tidiness and cleanliness in the assembly area! Loosely stacked or scattered components and tools are accident sources.

If components must be replaced:

- Pay attention to correct installation of spare parts.
- Properly reassemble all fastening elements.
- Observe screw tightening torques.
- Before restarting, ensure that all covers and protective devices are correctly installed and function correctly.
- After completion of maintenance work and troubleshooting, check correct functioning of safety equipment.

3 Technical data

General data	Unit	
Mass moment of inertia compressor	[kgm ²]	1.52 (CR) / 1.44 (CL)
Compressor weight	[kg]	123
Permissible inclination from the horizontal during operation	[°]	all sides ±7

Tab. 1: General data

Permissible working range	Unit	
Input speed	[min ⁻¹]	1000...1800
Suction temperature ¹⁾	[°C]	- 10...+ 40
Geodetic height ¹⁾	[m]	0...1000
Negative pressure suction side (e.g. due to soiling)	[mbar]	0...65
Maximum final overpressure at the pressure flange ²⁾	[bar]	2.5
Running time in continuous operation ³⁾	[h]	max. 3.0

1) For suction temperatures or heights outside the permissible working range, consult with CVS.

2) In case of increased suction temperatures or heights, the maximum permissible final pressure is reduced. Consult with CVS.

3) For continuous operation in excess of 3 hours, an oil cooler must be installed. Installation instructions on request.

Tab. 2: Permissible working range

Compressor performance data ¹⁾		Unit			
Input speed		[min ⁻¹]	1000	1400	1800
Intake volume flow at a final overpressure at the pressure flange	0.0 bar		620	920	1170
	2.5 bar		480	800	1045
Coupling power at a final overpressure at the pressure flange:	0.0 bar		10,0	16,0	22,5
	2.5 bar		35,0	49,5	64,5
Final temperature at final overpressure = 2.0 bar		[°C]	177	177	166
max. perm. final temperature at final overpressure = 2.5bar		[°C]	250		

1) Suction pressure at suction flange = 1.0 bar, suction and ambient temperature = 20 °C, geodetic altitude max. 1000 m

Tab. 3: Performance characteristics

Technical data

Gear oil specification	Value
Specification	API CD/SF or higher
SAE viscosity class	10W40 or 15W40
Oil pressure of compressor	min. 0.5 bar (excess pressure)
Gear oil quantity compressor	4.8 litres

1) When connecting a gear oil cooler, the oil quantity must be increased commensurate with the additional volume.

Tab. 4: Gear oil specification

Recommended gear oils	Brand	Type of oil
	MOBIL	Delvac MX Extra 10W40
	ARAL	Multi Turboral SAE 15W40
	DEA	Cronos Super DX SAE 15W40
	ESSO	Essolube XT 201 SAE 15W40
	SHELL	Universal Engine Oil SAE 15W40
	FUCHS	Titan Universal HD SAE 15W40
	BP	Vanellus C5 Global SAE 15W40

Other gear oil grades on request.

Tab. 5: Types of gear oil

4 Design and function

4.1 Design

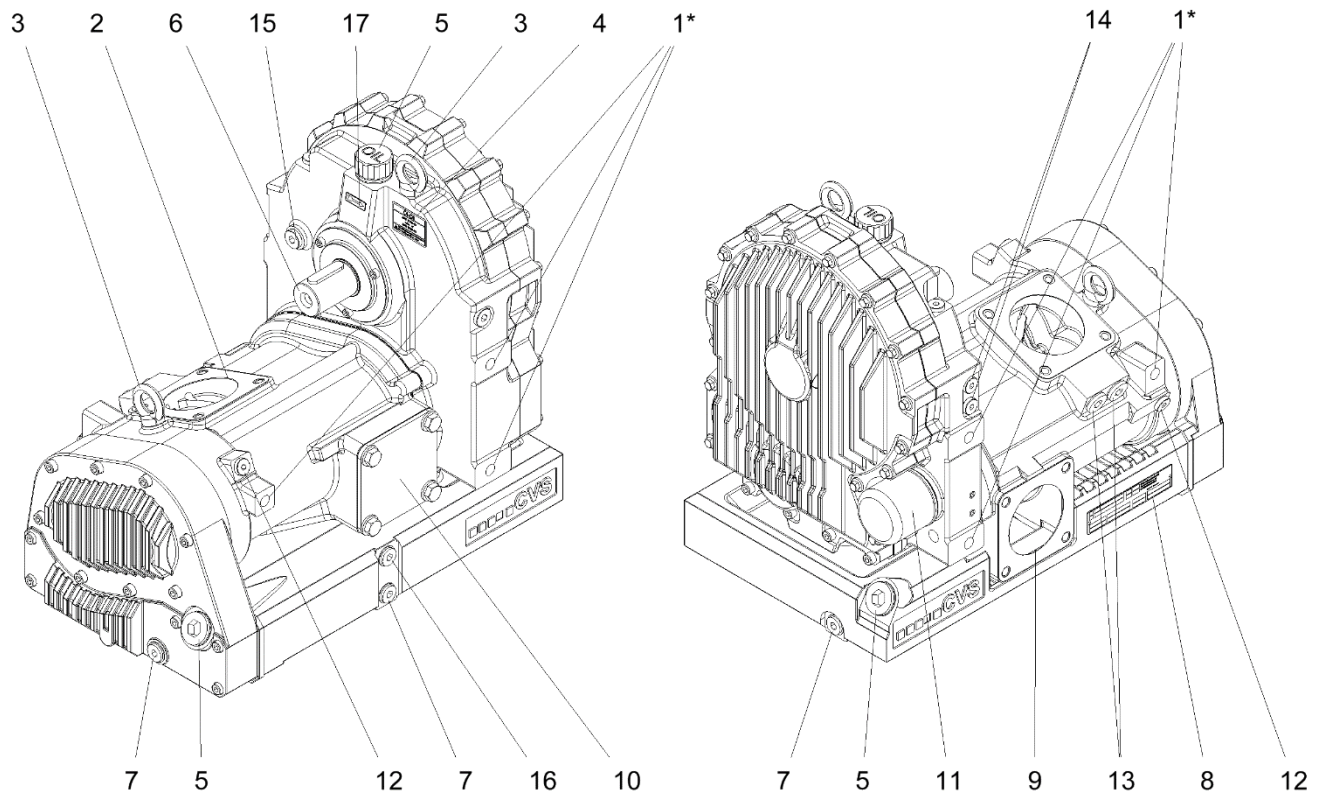

Fig. 1: Compressor view

- | | | | | | |
|---|--|----|-------------------------------|----|--|
| 1 | Fastening threads vertical (3 pieces on each side of the compressor) | 6 | Drive shaft with feather key | 13 | Connection pressure gauge or temperature sensor for compressed air |
| 2 | Air outlet flange | 7 | Oil drain screw | 14 | Connection of external oil cooler |
| 3 | Attachment point for transport | 8 | Rating plate data compressor | 15 | Lock pin for external oil cooler |
| 4 | Rating plate gear oil | 9 | Flange A air inlet | 16 | Control bore for oil filling |
| 5 | Oil filler neck cap / gearbox ventilation | 10 | Flange B air inlet (closed) | 17 | Rotation direction arrow |
| | | 11 | Gear oil filter | | |
| | | 12 | Connection oil pressure gauge | | |

Design and function

4.2 Function

Functional principle

Purified air is sucked in via flange A or B for air inlet. Two screw rotors compress the air completely dry. The rotors are running contact-free both in relation to each other and to the casing. They are kept apart by a synchronising gearbox. The compressed air reaches the consumer via the air outlet flange.

Lubrication

Bearing and gearbox are supplied with gear oil via an oil filter by means of an integrated oil pump.

Cooling

The heat is dissipated to the ambient air via the casing surface.

Drives

The drive is effected by means of an articulated shaft.

Sense of rotation

SKL 1200 CR

The drive shaft's sense of rotation is clockwise when looking onto the drive shaft.

SKL 1200 CL

The drive shaft's sense of rotation is counter-clockwise when looking onto the drive shaft.

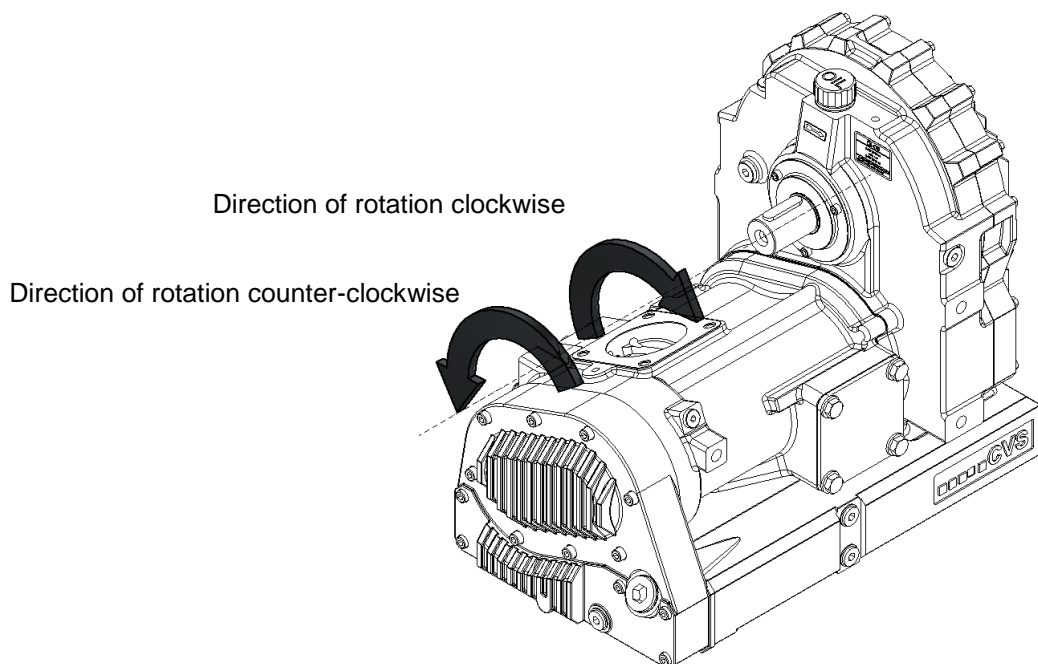

Fig. 2: Sense of rotation

4.3 Control and display elements

Depending on the installation location, different display elements such as pressure gauge, temperature gauge and negative pressure display are available.

5 Transport and storage

5.1 Safety notes for transport

See chapter 2.6 Safety!

5.2 Transport

The compressor must be transported with suitable lifting gear. Ropes or belts should preferably be fastened to the two eye bolts (M10).

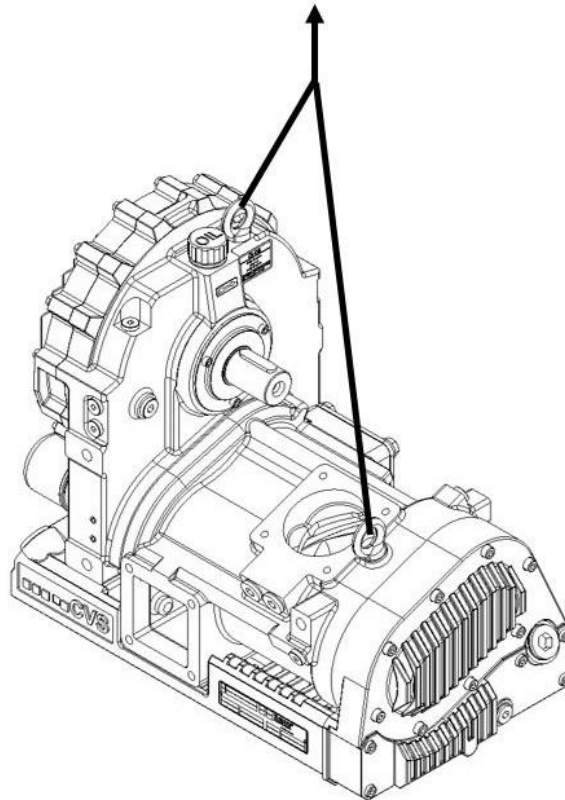

Fig. 3: Transport with lifting gear

For future transports

- Seal all open connections with protective caps (prevents penetration of dirt and water)
- Secure against vibrations
- Drain gear oil
- Securely fasten the compressor prior to transport (e.g. screw it onto a pallet)
- Transport and place the compressor with a sufficiently dimensioned lift truck or forklift truck or secure with straps and lift with suitable lifting gear.

Transport and storage

5.3 Storage

Storage of packages

Store packages under the following conditions:

- Do not store outdoors.
- Store dry and dust free.
- Do not expose to aggressive media.
- Protect against solar irradiation.
- Avoid mechanical vibrations.
- Storage temperature: -10 to +60 °C
- Relative humidity: max. 95%, non-condensing
- If storage lasts longer than 3 months, regularly check the general condition of all parts and of the packaging.
- On compressors intended for export (overseas), bags with desiccant are placed into the inlets and outlets. These bags keep moisture away from the compressor's working chambers. Remove bags before suction and pressure line are connected.

6 Start-up and operation

6.1 Safety during start-up

See chapter 2.6 Safety!

6.2 Start-up



ATTENTION!

The compressor must always have a sufficient oil level. Check oil level and top up if necessary. Refer to rating plate oil on the compressor or chapter 3 Tab. 4 / Tab. 5: Types of gear oil.

Inspection prior to initial start-up

The following points must be checked prior to initial start-up:

- Transport damage to the compressor
- Screw connections for tightness
- Oil level (refer to chap. 7.3)

Start-up

- Ensure that the compressor is positioned at an acceptable angle (see chapter 3 Tab. 1)
- Depressurise the pressure side
- Open shut-off devices
- Switch on drive (engage gently)
- Adjust input speed
- Check operating data

Inspections during operation

During operation **the operator** has to check the following data **every 20 minutes**:

- Drive speed (see chapter 3 Tab. 2)
- Final overpressure (see chapter 3 Tab. 2)
- Gear oil pressure at the compressor (see section 7.3)

Maintenance

6.3 Switching off

Switch the compressor off as follows:

- Switch off drive.
- Close shut-off valves, drain condensate if necessary, e.g. when using a compressed air aftercooler.

6.4 Inspections to be performed

Gear oil inspection

Check the gear oil level in the compressor. Top up with oil if necessary.

Non-return valve inspection

The non-return valve is maintenance free, but is subject to wear like any other moving part. We recommend a visual inspection every 3 months. In this connection, the non-return valve must be dismantled, cleaned, freed of deposits and checked for freedom of motion.

Safety valve inspection

**The safety valve is no regulating device!
The operational capability must be checked on start-up and later at weekly intervals.**

The safety valve must be secured against misadjustment. Blocking or manipulating the safety valve can have penal consequences if it gives rise to an accident. Any warranty claims shall also be forfeited in such a case.

The nominal opening pressure may not exceed the maximum permissible final overpressure (refer to chapter 3 Tab. 2) or the permissible system pressure, provided the latter is lower.

Functional testing is carried out by actuating the manual ventilation with the compressor running.

7 Maintenance

7.1 Safety during maintenance work

See chapter 2.6 Safety!

Personal protective equipment

The following must be worn during all maintenance work:

- Safety working clothing
- Protective gloves
- Safety shoes
- Safety goggles

Environmental protection

Observe the following information with regard to environmental protection during maintenance:

- Remove emerging, used or excessive grease at all lubricating points that are manually supplied with lubricant and dispose of in accordance with valid local regulations.
- Collect exchanged oil in suitable containers and dispose of in accordance with valid local regulations.

7.2 Maintenance schedule

The following describes the maintenance work that is necessary for an optimum, trouble-free operation. Maintenance intervals must be observed.

If increased wear of individual components or functional groups is determined during regular inspections, the operator has to reduce the required maintenance intervals on the basis of the actual signs of wear.

Changes compared to normal operation (increased power consumption, temperatures, vibrations, noises, etc. or response of monitoring systems) lead to the assumption that the functions are impaired. These then have to be subjected to an inspection by specialised staff.

In case of queries regarding the maintenance work and intervals: contact the manufacturer (service address → page 2).

For maintenance schedule refer to next page.

Maintenance

Maintenance schedule

Interval	Maintenance work	To be carried out by
Weekly	Check and clean compressor (see chapter 7.3)	Operator
	Check screw connections	
	Check gear oil level (see chapter 7.3)	
	Check the degree of contamination of the air filter (see chapter 3 Tab. 2)	
	Check connection to drive (articulated shaft, safety clutch) *	
	Check safety valve *	
quarterly	Clean compressed air after cooler or oil cooler, clean cooling air fins *	Specialised staff
half-yearly or every 500 h	Check non-return valve (refer to chap. 6.4)	
	Carry out gear oil change (refer to chap. 7.3)	
	Oil filter change (refer to chap. 7.3)	

* Observe manufacturer's recommendations

Tab. 6: Maintenance schedule

7.3 Performance of maintenance work

Cleaning the compressor

Observe the following when cleaning the compressor:

1. Switch off compressor and secure against restarting.
2. Remove contamination.
 - Do not use aggressive cleaning agents.
 - No water may penetrate into the compressor. Caution when using a high pressure cleaner.
 - After wet cleaning, warm up the compressor for a few minutes.

**Check oil level
Refill with oil**



ATTENTION!

To check the oil level, the vehicle must be level. The inclined position of the compressor specified by the installation is harmless.

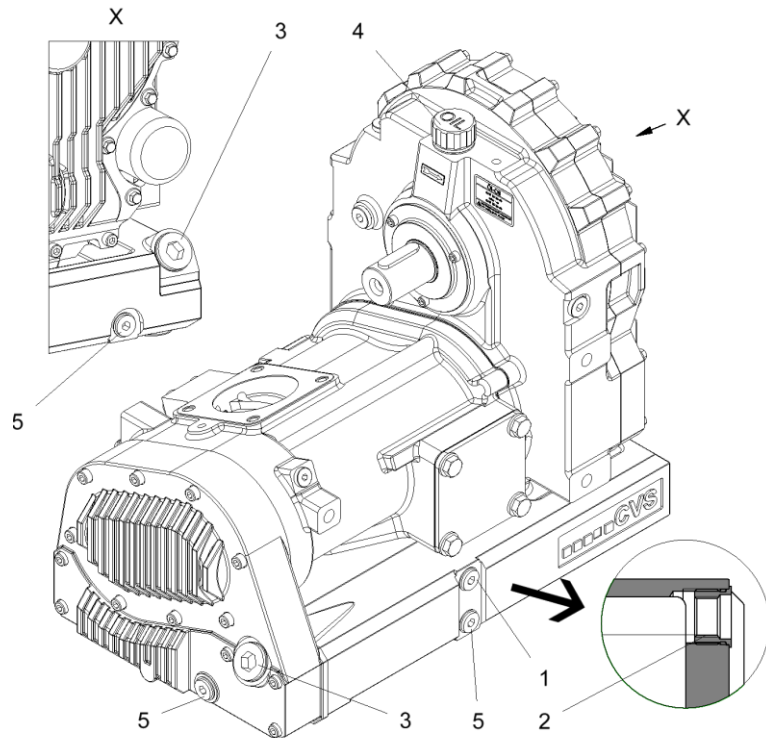

Fig. 4: Oil level and oil change

- Unscrew the upper screw plug (1) from the oil pan and check whether the oil reaches the lower edge of the threaded hole (2) (see magnification).
- Correct oil level if necessary.
If the oil level is too high: The oil flows out of the control bore. Collect oil and dispose of in accordance with legal regulations.
- If the oil level is too low: Top up with oil. To do this, either unscrew the higher of the two filling screws (3) or the vent plug (4) and slowly fill in the oil until the oil reaches the lower edge of the threaded hole (2).



ATTENTION!

When filling via the bore of the vent plug (4), the oil level changes only after a time delay due to the oil flowing in.

Maintenance



ATTENTION!

Use only specified oil. Refer to rating plate oil on the compressor or chapter 3 Tab. 4 and Tab. 5: Types of gear oil.



WARNING!

Risk of burns from hot oil!

Hot oil can cause serious personal injury.

Therefore:

Allow the gear oil to cool down before checking the oil level.

Change gear oil

- Open the oil drain screw (5) at the lowest point, drain oil.
- Dismantle oil filter with the aid of a strap wrench. Lightly oil the new oil filter on the rubber seal and tighten by hand.
- Close oil drain screws, fill in oil (see section 3 Tab. 4 and Tab. 5) as described above and check filling level.



WARNING!

Risk of burns from hot oil!

Hot oil can cause serious personal injury.

Therefore:

Allow the gear oil to cool before changing.

Safety valve inspection

The safety valve must be secured against misadjustment. Functional testing is carried out by actuating the manual ventilation with the compressor running.

Measures to be taken in the event of prolonged standstill

During a lengthier standstill, we recommend to put the compressor into operation once a week for approx. 15 minutes.

8 Malfuncions

This chapter describes possible causes of malfuncions and trouble shooting tasks.

Reduce the maintenance intervals if similar malfuncions occur repeatedly due to above-average intensive use so intervals correspond to the actual load.

Contact the manufacturer in case of malfuncions that cannot be repaired with the aid of the following information (→ page 2)!

8.1 Safety

Refer to chapter 2.6 Safety! Personnel

Personnel

- The trouble shooting work described at this point can be carried out by the operator, unless otherwise indicated.
- Some work may only be carried out by specially trained specialised staff or exclusively by the manufacturer himself. This is specifically pointed out in the description of the individual malfuncions.
- Only electrical specialists may carry out work on the electrical system.
- Components and parts may only be replaced by specialised staff.

Personal protective equipment

Refer to chapter 7.1.

Environmental protection

Refer to chapter 7.1.

Conduct in the case of malfuncions

The following basically applies:

1. Immediately switch off the compressor in case of malfuncions representing an immediate danger for individuals or material assets.
2. Switch of all power supplies and secure against restarting.
3. Inform person in charge at the place of installation.
4. Depending on the type of malfunction, have the cause determined and eliminated by responsible and authorised specialised personnel.

8.2 Recommissioning after corrective action

After corrective action or trouble shooting:

1. Ensure that nobody is staying in the hazard area.
2. Start in accordance with the instructions in chapter „start-up“.

Malfuncions

8.3 Malfunction table

Malfunction	Possible cause	Corrective action	Execution
Flow rate too low	Air filter soiled	Clean or replace filter cartridge	Operator
	Pressure line leaky	Eliminate leakage	Specialised staff
	Speed too low	Correct speed (see chapter 3 Tab. 2)	Operator
Abnormal noise emission	Misalignment vis-à-vis drive	Align compressor	Specialised staff
	Bearing defective	Replace bearing	Manufacturer
	Lack of lubricating oil	Top up with oil (see chapter 7.3)	Operator
	Unsuitable lubricating oil	Oil change (see chapter 7.3)	Operator
	Wrong speed	Correct speed (see chapter 3 Tab. 2)	Operator
	Foreign bodies in the compressor	Clean the compressor	Specialised staff
Compressed air temperature too high	Final pressure too high	Maintain perm. final pressure (see chapter 3 Tab. 2)	Operator
	Head loss in suction system too high	Clean or replace filter cartridge	Operator
	Final overpressure too high	Maintain maximum final overpressure (see chapter 3 Tab. 2) Check pressure line for clogging	Specialised staff
	Wrong speed	Correct speed (see chapter 3 Tab. 2)	Operator
Operating pressure is not attained	Pressure gauge defective	Replace pressure gauge	Specialised staff
	Leakage in the pressure line	Eliminate leakage	Specialised staff
	Wrong speed	Correct speed (see chapter 3 Tab. 2)	Operator
Power requirement too high	Pressure gauge defective	Replace pressure gauge	Specialised staff
	Speed too high	Correct speed (see chapter 3 Tab. 2)	Operator
	Final pressure too high	Maintain perm. final pressure (see chapter 3 Tab. 2)	Operator
Safety valve blows off	Shut-off valve not fully open	Fully open shut-off valve	Operator
	Pressure line clogged	Eliminate clogging	Operator
Oil pressure too low	Pressure gauge defective	Replace pressure gauge	Specialised staff
	Lack of lubricating oil	Top up with oil (see chapter 7.3)	Operator
	Operator Max. inclination exceeded	Correct inclination (see chapter 3 Tab. 1)	Operator
	Speed too low	Correct speed (see chapter 3 Tab. 2)	Operator
	Oil filter soiled	Replace oil filter	Operator
	Unsuitable lubricating oil	Top up with oil (see chapter 7.3)	Operator

Malfunction	Possible cause	Corrective action	Execution
Oil pressure fluctuates heavily	Lack of lubricating oil	Top up with oil (see chapter 7.3)	Operator
	Operator Max. inclination exceeded	Correct inclination (see chapter 3 Tab. 1)	Operator
	Unsuitable lubricating oil	Top up with oil (see chapter 7.3)	Operator

Tab. 7: Malfunction table

Spare parts

9 Spare parts

Customer Service

In case of queries regarding the product, spare part orders, repairs, replacement compressor and dispatch of fitters, please contact our customer service: Phone: +49 (0)7623 71741-31

10 Decommissioning and disposal

A compressor that is no longer usable should not be recycled as complete unit, but disassembled into individual components and recycled according to material types. Non-recyclable materials have to be disposed of in an environmentally compatible manner.

- Prior to decommissioning and disposal of the compressor, it must be completely separated from the surrounding units.
- The disassembly and disposal of the compressor may only be carried out by specialised staff.
- The compressor has to be disposed of in accordance with the respective country-specific regulations.

Index

Index

A	
Acceptance	8
C	
Cleaning	24
Components, moving	12
Compressed air	12
Contact person	7
Copyright protection	6
Customer Service	7
D	
Danger of burns	10
Danger pictograms	10
Dangers	10
Design	17
Design and function	17
Disposal	31
F	
Function	18
G	
Gear oil change	26
Gear oils, recommended	16
I	
Improper operation	11
Inspection	
before the initial start-up	21
during the operation	21
gear oil	22
non-return valve	22
safety valve	22
Inspection safety valve	26
Instructions	9
Intended use	8
L	
Liability	6
M	
Maintenance	22
Maintenance schedule	23
Maintenance work	24
Malfunction table	28
Malfunctions	27
O	
Occupational safety	10
Operating instructions	4
Operating personnel	9
Operator	8
P	
Personal protective equipment	22
Pneumatics	12
Protective equipment	10
R	
Recommissioning	27
S	
Safety	8
Signposting	12
Spare parts	7, 30
Specialists	9
Standstill lengthy	26
Start-up	21
Storage	19, 20
Switching off	22
Symbols in the instructions	5
T	
Technical data	15
Transport	19
W	
Warranty	6, 7