

Operating instructions

VacuStar W900 / W1300 / W1600

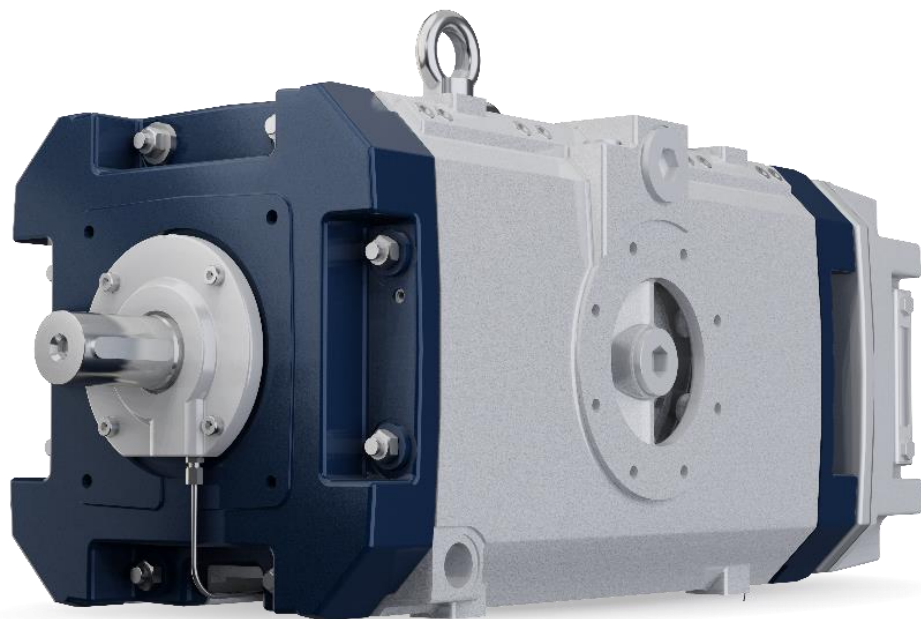

Doc-ID: 5002 / BA / EN

Release: Rev. 09 / 28.03.2023

The operating instructions must be read by the VacuStar W operator before start-up!

Translation of the original operating manual

© CVS engineering GmbH

Großmattstraße 14
79618 Rheinfelden / Germany

Phone: +49 (0)7623 71741-0
Customer service: +49 (0)7623 71741-0
E-Mail: info@cvs-eng.de
Internet: www.cvs-eng.de



1	General	4
1.1	Information regarding the operating instructions	4
1.2	Pictogram explanation	5
1.3	Limitation of Liability	6
1.4	Copyright protection.....	7
1.5	Spare parts	7
1.6	Warranty conditions	7
1.7	Customer Service	7
2	Safety	8
2.1	Intended use	8
2.2	Proper operation	8
2.3	Acceptance and monitoring	9
2.4	Operator's responsibility	9
2.5	Operating personnel	10
2.5.1	Requirements.....	10
2.6	Personal protective equipment	11
2.7	Occupational safety and special risks	11
3	Technical data	17
4	Design and function	18
4.1	Design.....	18
4.2	Function	19
4.3	Control and display elements	19
5	Transport and storage	20
5.1	Safety notes for transport	20
5.2	Transport.....	20
5.3	Storage	20
6	Start-up and operation	21
6.1	Safety during start-up	21
6.2	Start-up	21
6.3	Switching off.....	23
6.4	Inspections to be performed	24
7	Maintenance	26
7.1	Safety during maintenance work	26
7.2	Maintenance schedule	26
7.3	Performance of maintenance work	28
8	Malfunctions	32
8.1	Safety.....	32
8.2	Recommissioning after corrective action	33
8.3	Malfunction table.....	34
9	Spare parts	37
10	Decommissioning and disposal	38
	Index	39

1 General

1.1 Information regarding the operating instructions

These operating instructions provide important information on how to deal with the VacuStar W. A precondition for safe operation is the observance of all specified safety and handling instructions. Furthermore, all local accident prevention regulations and general safety regulations valid for the application area of the VacuStar W must be observed.

Carefully read the operating instructions before starting any work! It is a product component and must be kept in direct proximity of the VacuStar W, well accessible to the personnel at all times.

When passing the VacuStar W on to third parties, the operating instructions must also be handed over.

1.2 Pictogram explanation

Warning notes

Warning notes are characterised by pictograms in these operating instructions. The warning notes are marked by signal words expressing the extent of the hazard.

It is absolutely essential to observe the notes and to proceed with caution in order to prevent accidents as well as bodily injuries and property damage.



DANGER!

points to an immediately dangerous situation, which can lead to death or serious injuries if it is not avoided.



WARNING!

... points to an immediately dangerous situation, which can lead to death or serious injuries if it is not avoided.



CAUTION!

... points to a potentially dangerous situation, which can lead to minor or light injuries if it is not avoided.



ATTENTION!

... points to a potentially dangerous situation, which may lead to property damage if it is not avoided.



Safety note ATEX!

Only for machines with Ex-approval.
This pictogram denotes the special conditions that must be observed according to the approvals when operating the machines in potentially explosive areas.

Hints and recommendations



NOTE!

... highlights useful hints and recommendations as well as information for an efficient and trouble-free operation.

General

1.3 Limitation of Liability

All specifications and notes in these operating instructions were compiled with consideration to the valid standards and regulations, the state of the art as well as to our long-standing knowledge and experience.

The manufacturer is not liable for damages caused by:

- Non-observance of the operating instructions
- Improper use
- Deployment of non-trained personnel
- Arbitrary modifications
- Technical changes
- Use of non-approved spare and wear parts

The actual scope of supply may differ from the explanations and illustrations described in this manual in case of special designs, if additional order options are made use of, or due to latest technical changes.

Incidentally, the responsibilities agreed upon in the delivery contract, the general terms and conditions as well as the manufacturer's conditions of delivery and the statutory provisions valid at the time of contract conclusion shall apply.

Warranty

The manufacturer guarantees the correct functioning of the applied process technology and the performance parameters identified.

The warranty period commences on the date the VacuStar W is delivered to the customer.

Wear parts

Wear parts are all components coming into immediate contact with the material to be processed (e.g. bearings, shaft sealing rings, oil pumps, rotor vanes, etc.).

These components are excluded from the warranty and any claims for defects as far as wear and tear damage is concerned.

1.4 Copyright protection

Surrendering the operating instructions to third parties without written permission of the manufacturer is not permitted.



NOTE!

Content details, texts, drawings, pictures and other illustrations are protected by copyright and are subject to industrial property rights. Any improper use shall be liable to prosecution.

Any type and form of duplication also of extracts as well as the exploitation and/or communication of the contents are not permitted without the manufacturer's written declaration of consent.

1.5 Spare parts



WARNING!

Risk of injury by incorrect spare parts!

Incorrect or defective spare parts can result in damage, malfunctions or total failure and also impair safety.

Therefore:

- Use only the manufacturer's original spare parts.

Procure spare parts from authorised dealers or directly from the manufacturer. Refer to page 2 for address.

A list of spare and wear parts can be found in the enclosure.

1.6 Warranty conditions

The warranty conditions are included in the sales documentation as a separate document.

1.7 Customer Service

Our customer service can be contacted for any technical advice. Information about the responsible contact person can be retrieved by telephone, fax, E-mail or via the Internet at any time, refer to manufacturer's address on page 2.

Safety

2 Safety

2.1 Intended use

The compressor vacuum pumps of the VacuStar W series are exclusively intended for the compression or extraction of filtered air.

The VacuStar W in the explosion proof design complies with Directive 2014/34/EC (ATEX) and is suitable for conveying potentially explosive gases and gas mixtures of explosion group IIB, temperature class T2/T3 from potentially explosive zone 1 and zone 2 areas. The VacuStar W may not be operated in a potentially explosive area.

Marking of the VacuStar W:



Marking of II 2G c IIB T2 (i) (for VacuStar W without cell ventilation)

II 2G c IIB T3 (i) (for VacuStar W with cell ventilation and no potentially explosive external atmosphere).

The gas temperature in temperature class T2 is restricted to 220 °C and in temperature class T3 to 195 °C.

2.2 Proper operation



The following criteria in essence define the proper operation:

- Speed range of the VacuStar W:
1000...1500 min⁻¹
- Ambient temperature: -20...+40 °C
- No coast down of the cooling system after switching off the VacuStar W
- Permissible continuous duty vacuum with cell ventilation: 100 mbar
- Permissible continuous duty vacuum without cell ventilation: 200 mbar
- No back pressure on the pressure side during vacuum operation
- Liquids and solids may not get into the VacuStar W or be sucked into the VacuStar W.



If explosive gases and gas mixtures are conveyed, the following guidelines must be observed:

- 2014/34/EC
Devices and protection systems for the proper use in explosive environments
- 99/92/EC
Health protection and safety of the employees in potentially explosive areas

Only use VacuStar W for the intended use.

All specifications in these operating instructions have to be strictly complied with (technical data, ATEX regulations, etc.)

All types of claims due to damage arising from improper use are excluded. The operator alone shall be responsible for any damage arising from improper use.

2.3 Acceptance and monitoring

The VacuStar W itself is not subject to any acceptance and monitoring obligation.

2.4 Operator's responsibility

The VacuStar W is used for industrial purposes. The operator of the VacuStar W is therefore subject to the legal obligations concerning occupational safety.

The provisions valid at the place of installation as well as the safety and accident prevention regulations of the Institution for statutory accident insurance and prevention must be observed. The operator must in particular:

- inform himself on the valid industrial safety regulations.
- determine the additional hazards that arise from the special working conditions at the machine's place of installation by means of a hazard assessment.
- implement the necessary rules of conduct for operation of the machine at the place of installation by means of user instructions.
- check at regular intervals during the machine's entire period of use whether the user instructions correspond to the current state of the body of rules and regulations.
- adapt the operation instructions, if necessary to the new regulations, standards, and operating conditions .
- clearly regulate the responsibilities for installing, operating, maintaining and cleaning the device.

Safety

- ensure that all employees working on or with the machine have read and understood the operating instructions. In addition he must at regular intervals train the employees in how to deal with the machine and inform them about potential hazards.

In addition, it is the operator's responsibility to ensure that:

- the machine is always in a technically perfect condition.
- the machine is maintained in accordance with specified maintenance intervals.
- all safety equipment is regularly checked for completeness and correct functioning.

2.5 Operating personnel

2.5.1 Requirements



WARNING!

Risk of injury in case of inadequate qualification!

Improper handling can lead to considerable bodily injuries and property damage.

Therefore:

- Have any activities only carried out by the individuals designated for that purpose.

The operating instructions specify the following qualification requirements for the different fields of activity:

- **Instructed persons**
have been instructed during instructions provided by the operator with regard to the work assigned to them and possible hazards arising from improper conduct.
- **Specialists**
are due to their technical training, knowledge and experience and their knowledge of the pertinent regulations able to carry out the work assigned to them and to independently recognize potential hazards.

2.6 Personal protective equipment

When handling the VacuStar W, it is necessary to wear personal protective equipment, in order to minimise health hazards.

- Before carrying out any work, properly don the necessary protective equipment such as gloves, safety goggles, etc. and wear during work.

2.7 Occupational safety and special risks

The remaining risks that result from the hazard analysis are specified in the following section.

Observe the safety notes listed here and the warning notes in the other chapters of these instructions to reduce health hazards and to avoid dangerous situations.

Danger pictograms on the device

The relevant dangerous spots on the machine are identified by these pictograms:



DANGER!

General danger pictogram!

... denotes general dangerous situations for individuals. Non-observance of the safety instructions can result in severe injuries or death.



DANGER!

Explosion protection pictogram!

... denotes regulations and information that need to be observed in potentially explosive areas. Explosion protection class, temperature ranges, etc. must be observed!



DANGER!

Danger of burns!

... denotes the presence of a hot surface.

Safety

Hazard notes and occupational safety

For your own safety and that of the machine, the following information must be observed and complied with:

Improper operation



DANGER!

Danger due to improper operation!

- Only use VacuStar W in a perfect technical condition. Malfunctions that are relevant for safety have to be promptly eliminated.
- Conversions of the VacuStar W are not permissible and can impair safety.
- Never bridge any safety equipment or put it out of operation.
- Any work on the VacuStar W and/or on electrical equipment must be carried out by specialised staff.
- Repair and maintenance work may only be carried out when the VacuStar W is stationary.

For this, the VacuStar W must be secured against restarting!

- The VacuStar W may not be under pressure or in a state of vacuum while work is being carried out on it.

Close shut-off valve on the vehicle side and vent the pipe between VacuStar W and shut-off valve or manually relieve excess pressure at safety valve. Observe pressure gauge!

- The drive's protective equipment may only be removed when the VacuStar W is stationary and has to be correctly refitted after completion of work.
- Only dismantle accidental contact protection after VacuStar W and pressure pipe have cooled down.
- It is an environmental protection requirement that any liquids arising during maintenance work (e.g. cooling oil, cooling water, etc.) are collected and disposed of in an environmentally compatible manner.
- The machine may only be opened for maintenance and repair work by specialised staff if the VacuStar W is stationary and no potentially explosive atmosphere is present.



Moving components

WARNING!
Risk of injury by moving components!

Powered rotating components can cause the most serious injuries!

Therefore during operation:

- It is absolutely forbidden for persons to stay in the hazard area or in the immediate vicinity!
- Do not put safety devices and/or functions out of operation and do not render them inoperative or bypass them.
- Never reach into open outlets and inlets or into running equipment.

Before entering the hazard area:

- Switch off power supply and secure against restarting.
- Wait for standstill of lagging components.
- Wait for automatic dissipation and/or discharge of residual energies (compressed air).

Compressed air

WARNING!
Risk of injury due to compressed air!

Pneumatic energies can cause the most serious injuries.

In the case of damage to individual components, air can be discharged under high pressure and injure e.g. the eyes.

Therefore:

- Before starting any work, first depressurise pressurised components. Pay attention to accumulators. Accumulator pressure must also be completely relieved.
- Do not change pressure settings beyond the maximum values.

Safety

Signposting



WARNING!

Risk of injury by illegible pictograms!

Labels and signs can become dirty or unrecognisable in the course of time.

Therefore:

- Always keep safety, warning and operating instructions in a well legible condition.
- Immediately replace damaged or obliterated signs or labels.

Improper transport



Danger!

Danger by falling down or tilting of the VacuStar W!

The weight of the VacuStar W may injure a person and cause serious bruising!

Therefore:

- Depending on the dead weight and size of the VacuStar W, use a pallet on which the VacuStar W can be moved by means of a fork lift.
- For lifting the VacuStar W, use suitable lifting gear (slings, etc.) that is designed for the weight of the VacuStar W.
- When putting the slings in position, take care to avoid putting stress on individual components.
- Only use the provided attachment points with eye bolts.

Start-up, operation

WARNING!
Risk of injury due to improper start-up and operation

Improper start-up and operation can lead to serious bodily injuries or property damage.

Therefore:

- Have all work during initial operation exclusively performed by the manufacturer's employees or by his authorised representatives or by trained personnel.
- Start-up and operation may only be performed by adequately qualified personnel that has been authorised and instructed by the operator.
- Before the start of any work, ensure that all covers and protective devices are correctly installed and function correctly.
- Never override any protective equipment during operation.
- Pay attention to tidiness and cleanliness in the working area! Loosely stacked or scattered components and tools are accident sources.

Electrical system

DANGER!
Mortal danger due to electric current!

There is mortal danger in case of contact with live components.

Activated electrically driven components can start to move uncontrolled and cause severest injuries.

Therefore:

- Switch off the electric power supply before commencing any work and secure against restarting.
- Work on the electrical system, on individual electrical components and on the connections may only be carried out by electrical specialists.

3 Technical data

VacuStar W operating data	Unit	Model W900	Model W1300	Model W1600
Speed range	[min ⁻¹]	1000...1500		
Nominal operating vacuum	[mbar]	400	400	400
Permissible continuous duty vacuum ¹	[mbar]	100	100	100
Maximum final overpressure during compressor operation in case of direct drive ²	[bar]	2	2	2
Maximum final overpressure during compressor operation in case of V-belt drive ²	[bar]	2	1.5	0.5
Oil reservoir	[l]	7.5	7.5	7.5
Lubricating oil consumption	[l/h]	0.2	0.3	0.4
Weight (without accessories)	[kg]	220	279	339

Tab. 1: Operating data

Lubricating oils

The use of multigrade oils will damage the VacuStar W. In that case, the warranty on the part of CVS Engineering GmbH shall cease. Only single grade oils with the following specification are permitted for operating the VacuStar W:

Specification	Value
API:	CF/CF4 or higher
ACEA:	E2 or higher
Viscosity:	Suction temperature > 10 °C: SAE 40 Suction temperature < 10 °C: SAE 30

Tab. 2: Lubricating oils

Recommended oil types

Brand	Suction temp. > 10 °C	Suction temp. < 10 °C
CVS	CVS Lube 4000	CVS Lube 3000

Other oil types on request.

Tab. 3: Lubricating oil types



ATTENTION!

Do not use any synthetic lubricants!

¹ Only in conjunction with cell ventilation, without cell ventilation 200mbar (protection via ventilation valve)

² Protection via a safety valve

Design and function

4 Design and function

4.1 Design

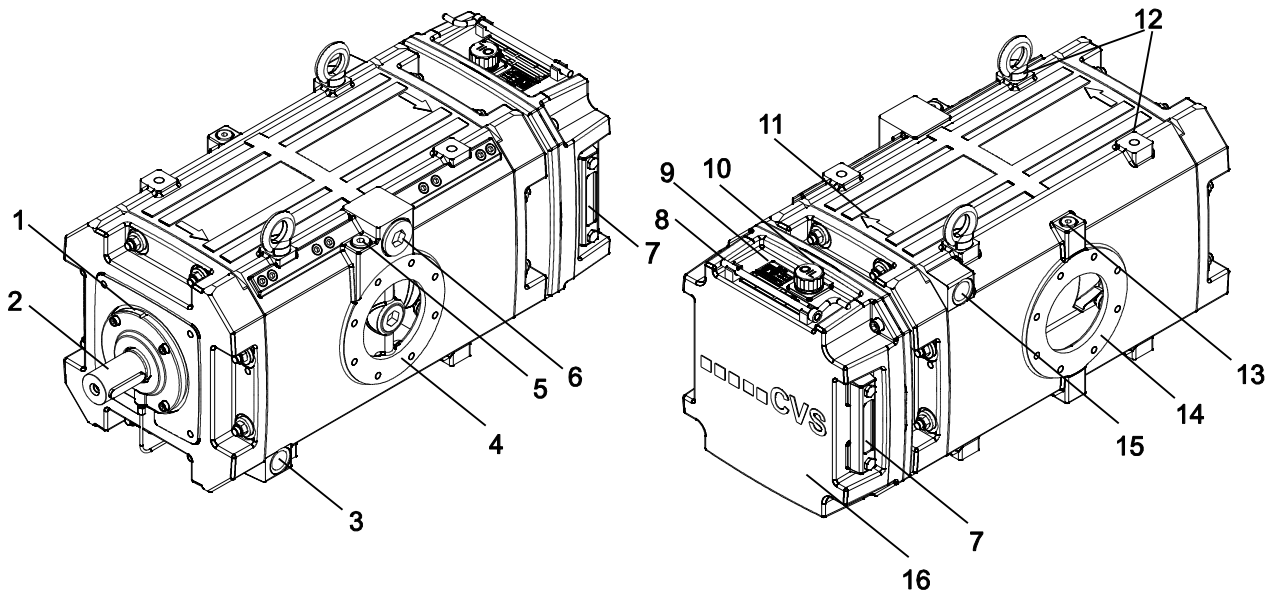

Fig. 1: View VacuStar W and details

- | | | |
|--|--------------------------------------|--|
| 1 Centring device and fastening of hydraulic motor mounting flange | 6 Connection cell ventilation (R 2") | 12 Transport and fixing holes (M16) |
| 2 Drive shaft | 7 Oil level indicator (bilateral) | 13 Negative pressure connection (R 3/8") |
| 3 Cooling water inflow (1") | 8 Crank for manual lubrication | 14 Suction connection (flange DIN 28459-125) |
| 4 Pressure connection (flange DIN 28459-125) | 9 Rating plate | 15 Cooling water outflow (R 1") |
| 5 Temperature measuring point (R 1/2") | 10 Oil filler neck cap | 16 Lubricating oil reservoir |
| | 11 Rotation arrow | |

4.2 Function

Functional principle

Sliding vane compressor vacuum pumps work according to the displacement principle.

Due to the rotor's eccentric arrangement inside the casing, limited, crescent-shaped working chambers are created by means of the rotor vanes, which are enlarged or reduced with every turn of the rotor.

Cleaned air is drawn in via the suction connection (item 14) and reaches the pressure line after being compressed via the pressure connection (item 4).

Lubrication of the VacuStar W

The VacuStar W is lubricated by means of an oil pump. Oil is pumped from the oil reservoir via the oil lines to the VacuStar W's lubricating points.

Cooling

The VacuStar W is water-cooled. The VacuStar W is equipped with a cooling jacket inside the casing. The cooling water circulates by means of a circulating pump.

Drives

The VacuStar W can be powered via:

- Articulated shaft
- V-belt
- Hydraulic motor

Details about the drives and their design can be found in the separate mounting instructions for the VacuStar W.

4.3 Control and display elements

Depending on the installation situation, different display elements such as pressure gauge, temperature gauge and vacuum gauge are available.

5 Transport and storage

5.1 Safety notes for transport

See chapter 2.7 Safety!

5.2 Transport

The VacuStar W fastened on a baseplate must be transported by means of a fork lift or suitable lifting gear. The lifting gear must be designed for the weight of the VacuStar W.

For future transports:

- Seal all open connections with protective caps (prevents penetration of dirt and water)
- Secure loose cables
- Secure against vibrations
- Drain all process and operating media
- Securely fasten the VacuStar W prior to transport (e.g. screw it onto a pallet)
- Transport and put down the VacuStar W with a fork lift or secure with straps and lift with suitable lifting gear.

5.3 Storage

Storage of packages

Store packages under the following conditions:

- Do not store outdoors.
- Store dry and dust free.
- Do not expose to aggressive media.
- Protect against solar irradiation.
- Avoid mechanical vibrations.
- Storage temperature: -10 to $+60$ °C
- Relative humidity: max. 95%, non-condensing
- If storage lasts longer than 3 months, regularly check the general condition of all parts and of the packaging. If necessary, brush up or recondition the preservation.
- To keep moisture away from the machine's workspace, bags with desiccant must be placed into the inlets and outlets. These must be removed before start-up.

6 Start-up and operation

6.1 Safety during start-up

See chapter 2.7 Safety!

6.2 Start-up

Inspection prior to initial start-up

The following points must be checked prior to initial start-up:

- Fill in **cooling water (clean tap water)** up to the maximum mark on the compensation reservoir.

Add antifreeze according to manufacturer's specifications.

- Top up **lubricating oil** according to lubricating oil schedule. Fill oil reservoir with oil up to max. 3 cm below filler neck thread.

Manually prelubricate the VacuStar W by means of the crank handle (refer to lubricating oil inspection Chapter 6.4).

Start-up

Proceed as follows during start-up:

- Open shut-off devices (if available)
- Start the VacuStar W drive
- Check operating data

Start-up and operation

Inspections during operation

The following inspections have to be carried out during operation:

- Prior to every start-up and during operation, the oil level and the coolant level must be checked and topped up if necessary.
- Open shut-off devices. Always turn the four-way cock until it hits the stop. Intermediate positions are not permitted
- Switch on drive and check whether pressure or vacuum are created.
- Pay attention to abnormal noises and leaks during operation. If necessary, switch off VacuStar W.
- Drain condensate at the condensate and safety traps. Vessel may not be in a state of vacuum when condensate is drained.

Checking the operating data:

- The speed must be between 1000...1,500 min⁻¹
- The cooling water outlet temperature (return flow to radiator) may be max. 60 °C.
- Check positive working pressure at the pressure gauge (permissible pressure refer to rating plate).
- Check the operating vacuum at the vacuum meter (permissible vacuum refer to rating plate).
- The compression end temperature at 20 °C suction temperature may not exceed the following values:
 - 140 °C at 400 mbar operating vacuum
 - 120 °C at 0.5 mbar excess pressure



If potentially explosive gases and gas mixtures are conveyed, the following points must be observed:

- Prior to every VacuStar W start and during operation:
 - Check coolant
 - Check oil level
 - Check for leaks
- Listen for abnormal noise during the suction process. Switch off the VacuStar W if necessary.
- Check the VacuStar W at regular intervals (daily) for signs of overheating and exceptional deformations. If necessary, switch off the VacuStar W or do not put it into operation.
- Regularly examine the VacuStar W for leaks such as leaking oil or water or escaping gas. If necessary, switch off VacuStar W or do not put into operation.
- If the VacuStar W is extremely hot: Switch off VacuStar W and only switch on again after approximately half an hour, to prevent the rotor from starting.

6.3 Switching off

To switch off the VacuStar W, proceed as follows:

- Switch off drive for the VacuStar W
- Close shut-off valves (if available)

Start-up and operation

6.4 Inspections to be performed

Lubricating oil inspection

Only lubricating oils pursuant to the lubricants specifications on page 17 are approved for the VacuStar W series.

Östand am Schauglas kontrollieren und falls erforderlich bis ca. 3 cm unter Gewinde des Einfüllverschlusses mit Öl füllen. The oil level may not drop below the bottom mark on the oil inspection glass.

Manual prelubrication of the VacuStar W is always necessary:

- in case of initial operation
- in case of recommissioning after a standstill of more than 4 weeks
- after sucking over of foreign matter
- after repair work on the VacuStar W

Procedure to be followed for manual prelubrication:

- Remove the crank handle from the retaining bracket and push it through the oil filler neck onto the oil pump shaft. Push the crank handle down until the drive dog engages and now prelubricate for approximately 40 full turns.
- Afterwards, clip crank handle back into the retaining bracket and screw locking screw back on again.

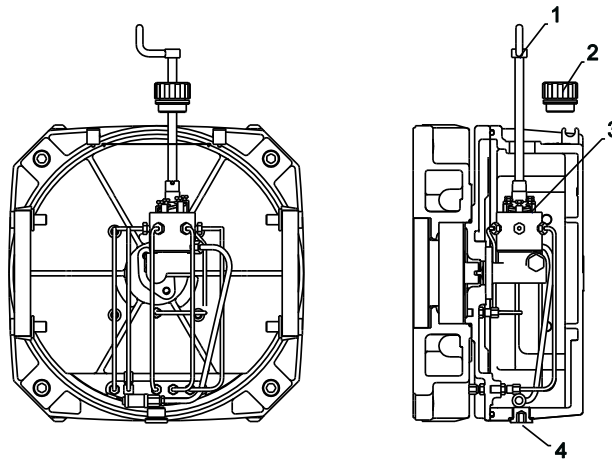

Fig. 2: Oil pump

- | | | | |
|---|-----------------------|---|-----------------------------|
| 1 | Crank handle | 3 | Lubricating oil pump |
| 2 | Oil filler neck screw | 4 | Lubricating oil drain screw |

The oil reservoir must be filled up before every suction process!



Non-return valve inspection

The non-return valve is maintenance-free, but is subject to wear like all other moving parts. We recommend a visual inspection every 6 months. In this connection, the non-return valve must be dismantled, cleaned, freed of deposits and checked for freedom of motion.

Prior to assembly, the cylinder pin's slide face must be brushed with Loctite No. 8065 lubricant.

Worn out non-return valves must be replaced!

Safety valve inspection

The safety valve is no regulating device!

The operational capability must be checked on start-up and later at weekly intervals.

The safety valve must be secured against misadjustment.

Blocking or manipulating the safety valve can have penal consequences if it gives rise to an accident. Any warranty claims shall also be forfeited in such a case.

A maximum pressure pursuant to rating plate is permissible.

Depending on the type of drive, this may according to the table Technical data on page 17 lower.

Inspection of the ventilating valve

As a matter of principle, a ventilating valve must be installed as safety element on the VacuStar W's suction side. When the set vacuum is reached, the ventilating valve opens and admits atmospheric auxiliary air into the system. The operational capability must be checked weekly with the aid of a vacuum meter at the VacuStar W's inlet. In case of systems without cell ventilation, the vacuum may not drop below the permissible value of 200 mbar.

In case of systems with cell ventilation, the vacuum may not drop below the permissible value of 100 mbar.

Inspection of cell ventilation

The VacuStar W has been prepared for operation with cell ventilation. The connection is located at the upper part of the pressure flange. If your system's cell ventilation is connected, you may operate the VacuStar W up to a vacuum of 100 mbar. A suction filter is located in the cell ventilation line. The filter must be cleaned weekly and replaced in case of visible damage.

7 Maintenance

7.1 Safety during maintenance work

Personal protective equipment	<p>See chapter 2.7 Safety!</p> <p>The following must be worn during all maintenance work:</p> <ul style="list-style-type: none">■ Safety working clothing■ Protective gloves■ Safety shoes■ Safety goggles
Environmental protection	<p>Observe the following information with regard to environmental protection during maintenance:</p> <ul style="list-style-type: none">■ Remove emerging, used or excessive grease at all lubricating points that are manually supplied with lubricant and dispose of in accordance with valid local regulations.■ Collect exchanged oil in suitable containers and dispose of in accordance with valid local regulations.

7.2 Maintenance schedule

The following describes the maintenance work that is necessary for an optimum, trouble-free operation. Maintenance intervals must be observed.

If increased wear of individual components or functional groups is determined during regular inspections, the operator has to reduce the required maintenance intervals on the basis of the actual signs of wear.

Changes compared to normal operation (increased power consumption, temperatures, vibrations, noises, etc. or response of monitoring systems) lead to the assumption that the functions are impaired. These then have to be subjected to an inspection by specialised staff.

In case of queries regarding the maintenance work and intervals: contact the manufacturer (service address → page 2).

For maintenance schedule refer to next page.

Interval	Maintenance work	To be carried out by
Every 15 minutes	Check operating speed	Operator
	Check operating pressure / vacuum	
	Check air outlet temperature	
	Check cooling water return temperature	
Daily	Check condensate	Operator
	Check safety trap	
	Check silencer oil trap	
	Check oil level and top up with fresh oil if necessary	
	Check coolant	
Weekly	Check safety valve	Operator
	Check ventilating valve	
	Clean cooling unit / water cooler	
	Clean VacuStar W	
	Clean vacuum filter	
	Check V-belt, V-belt tension and re-tension if necessary	
Monthly	Clean cell ventilation filter, replace if damaged	Operator
	Clean oil tank	
	Check fastening screws and tighten if necessary	
quarterly	Check shaft sealing rings for tightness (no oil may leak from them)	Specialised staff
	Check rotor vanes (wear)	
Half-yearly	Check cell ventilation valve	Specialised staff
	Check non-return valve of VacuStar W	
10,000 oh / 3 years	Replace shaft sealing rings	Specialised staff
15,000 oh / 5 years	Replace bearings	Specialised staff

Tab. 4: Maintenance schedule

Maintenance

7.3 Performance of maintenance work

Cleaning the VacuStar W

Carrying out cleaning work:

1. Switch off system and secure against restarting.
2. Remove soiling appropriately. Observe the following:
 - Do not use aggressive cleaning agents.
 - Pay attention during cleaning that no water gets into the compression chamber.
 - Exercise special caution when cleaning with high-pressure cleaning systems.
 - Absorb oil deposits with oil-absorbing materials (e.g. sawdust).
 - After cleaning work, check that all previously opened covers and safety equipment are correctly installed and function correctly.
 - After wet cleaning, warm up the VacuStar W for a few minutes.

Water cooling system /cleaning the radiator

Check cooling water level in compensation reservoir and top up if necessary.

Clean radiator in case of soiling as the cooling air must have free passage.

Action after lengthy standstill

If the standstill of the VacuStar W installed inside the vehicle lasts for more than a month, we recommend putting the VacuStar W into operation once a month for 15 minutes. The VacuStar W must be prelubricated prior to start-up (refer to chapter lubricating oil inspection, chapter 6.4.)

Action after sucking over of foreign matter

If foreign matter has been sucked over into the VacuStar W, proceed as follows:

- Unscrew locking screw in inlet or dismantle fitted additional lubrication line.
- Open vehicle box to allow the VacuStar W to be run without vacuum or pressure build-up.
- Switch on VacuStar W and allow approx. 0.5...1 l of a diesel-oil-mixture (1:1 mixing ratio) to be sucked into the VacuStar W through the hole in the inlet at approx. 1000 min⁻¹.
- Afterwards, allow another 0.5 - 1 l clean oil to be sucked in via the inlet.
- Completely remove this diesel-oil-mixture from the VacuStar W and do not allow to collect in the downstream silencer - fire hazard!
- Switch off VacuStar W and re-attach locking screw.
Prelubricate VacuStar W pursuant to chapter Lubricating oil inspection, chapter 6.4 before the VacuStar W is restarted.

Cleaning suction filter

Clean the suction filter depending on accumulated dirt or specification in the maintenance schedule.

Disassembly:

Release the cross-handle (1) to open the suction filter. 5 cross-handles (1) must be released in the pressure-right design. Remove the lid (2), hexagon nut (5), washer and filter element (4).

Cleaning:

- Wash the lid (1) and housing (3) with cleaning agents.
- Wash the coarse filter element (4) with cleaning agents and blow it out with compressed air from the inside outwards.
- Blow the fine filter element (4) out carefully with compressed air from the inside outwards.
- Do not tap out the filter element (4). Check for damage after cleaning. Replace damaged filter elements.

NOTE!

Pay attention during cleaning that no liquid, dirt or other objects get into the VacuStar W.

Maintenance

Assembly:

- Inserting the filter element (4)
- Install the washer and the hexagon nut (5). Press the filter element (4) well against the housing (3) and tighten the hexagon nut (5) manually. Turn the nut (5) by about 0.5 to 1 turn onwards with a wrench.
- Installing the round seal (6) at the lid (2)
- Insert the lid (2) into the housing (3). Tighten the cross-handle (1) or cross-handles (1) well manually.

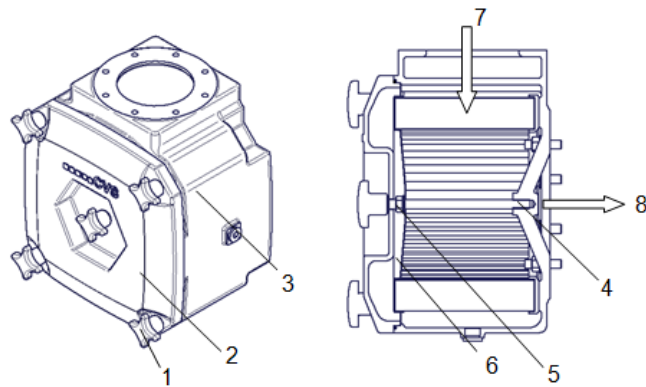

Fig. 3: Suction filter

- | | | | |
|---|----------------|---|-----------------------|
| 1 | Star handle | 5 | Hexagon nut |
| 2 | Lid | 6 | Round seal ring |
| 3 | Casing | 7 | Air inlet (dirt side) |
| 4 | Filter element | 8 | Air exit (clean side) |

Check rotor vane's height wear

Carry out the first inspection either after 6 months or after 500 operating hours, depending on which occurs first. The following inspection has to be scheduled according to the measuring result.

NOTE!

Pay attention during the inspection that no liquid, dirt or other objects get into the VacuStar W.

Procedure:

- Dismantle vacuum filter and if necessary suction line.
- Press rotor vanes into the rotor slit in horizontal position and measure the distance to the rotor surface with the depth gauge.
- The wear measurement of 6 mm may not be exceeded. Replace rotor vane if necessary.

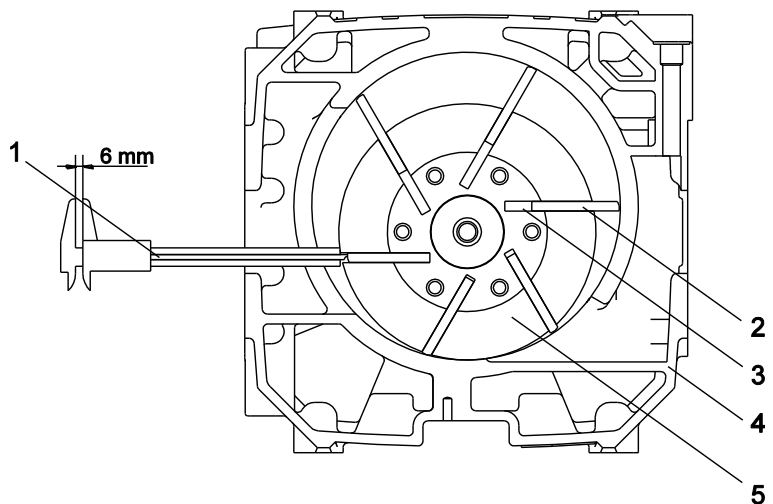

Fig. 4: Cross-section through the VacuStar W

- | | | | |
|---|-------------------------|---|--------|
| 1 | Depth gauge (max. 6 mm) | 4 | Casing |
| 2 | Rotor vane (6x) | 5 | Rotor |
| 3 | Rotor slit (6x) | | |

8 Malfunctions

This chapter describes possible causes of malfunctions and troubleshooting tasks.

Reduce the maintenance intervals if similar malfunctions occur repeatedly due to above-average intensive use so intervals correspond to the actual load.

Contact the manufacturer in case of malfunctions that cannot be repaired with the aid of the following information (→ p. 2)!

8.1 Safety

Personnel

Refer to chapter 2.7 Safety! Personnel

- The trouble shooting work described at this point can be carried out by the operator, unless otherwise indicated.
- Some work may only be carried out by specially trained specialised staff or exclusively by the manufacturer himself. This is specifically pointed out in the description of the individual malfunctions.
- Only electrical specialists may carry out work on the electrical system.
- Components and parts may only be replaced by specialised staff.

Personal protective equipment

Refer to chapter 7.1.

Environmental protection

Refer to chapter 7.1.

Conduct in the case of malfunctions

The following basically applies:

1. Immediately trigger an emergency-stop in case of malfunctions constituting an immediate danger for individuals or material assets.
2. Switch of all power supplies and secure against restarting.
3. Inform person in charge at the place of installation.
4. Depending on the type of malfunction, have the cause determined and eliminated by responsible and authorised specialised personnel.

8.2 Recommissioning after corrective action

After corrective action or trouble shooting:

1. Reset emergency stops.
2. Acknowledge error message or malfunction at the control system.
3. Ensure that nobody is staying in the hazard area.
4. Start in accordance with the instructions in chapter „start-up“.

Malfuctions

8.3 Malfunction table

Malfunction:	Possible cause	Corrective action	Execution
VacuStar W's delivery rate decreases.	Vacuum filter soiled	Clean vacuum filter	Operator
	Leaky suction line / fittings	Look for leaky spots and eliminate leak	Specialised staff
	Speed too low	Adjust speed	Operator
	Wear of rotor vanes, possibly caused by dirt or liquids that have gotten into the VacuStar W (sucking over of foreign matter)	Replace rotor vane, remove dirt and have VacuStar W overhauled at an authorised workshop	Specialised staff
Abnormal noise emission	VacuStar W is badly aligned.	Align the VacuStar W precisely.	Specialised staff
	Bearing defective	Replace bearing (or have it replaced)	
	Lack of lubricating oil	Top up oil, clean oil reservoir and suction filter	Operator
	Unsuitable lubricating oil	Fill in oil according to lubrication schedule	Operator
	Rotor vanes are jammed	Check rotor vanes	Specialised staff
	Casing bore shows grooves or corrugations due to the aspiration of dirt	Have casing bore re-turned and honed at an authorised workshop. In case of heavily soiled intake air, install fine filter	Specialised staff
	Wrong speed	Maintain speed range	Operator
	Changed pressure	Maintain nominal pressure	Operator
	Changed vacuum	Maintain nominal vacuum, check exhaust system and clean if necessary	Operator
	Non-return valve rattles	Check non-return valve	Specialised staff
	Foreign bodies in the VacuStar W	Remove foreign matter. Flush out the VacuStar W.	Specialised staff
Slide breakage	Switch off the VacuStar W at once and repair it.	Specialised staff	
Cooling water temperature exceeds 60°C	Too little cooling water in cooling system	Top up cooling water	Operator
	Radiator soiled or cooling water chambers silty	Clean radiator, clean cooling water chambers	Operator

Malfunctions

Malfunction:	Possible cause	Corrective action	Execution
Compressed air temperature too high	End pressure too high	Maintain nominal pressure	Operator
	Exhaust silencer clogged	Replace exhaust silencer	Specialised staff
	Four way cock in wrong position	Correctly adjust four way cock	Operator
	Poor cooling	Replenish cooling water, clean radiator, clean cooling water chamber inside the VacuStar W	Operator
	Valve plate in non-return valve is jammed	Check non-return valve and clean if necessary	Specialised staff
	Vacuum filter clogged	Clean vacuum filter	Operator
	Vacuum too high	Maintain nominal vacuum	Operator
Operating pressure or operating vacuum is not obtained	Pressure gauge or vacuum meter do not indicate correctly	Replace pressure gauge or vacuum meter	Specialised staff
	V-belts are slipping	Check V-belt tension and re-tension if necessary	Operator
	Four way cock in wrong position	Correctly adjust four way cock	Operator
	Condensate drain cock open	Close condensate drain cock	Operator
Silt or liquid has gotten into the VacuStar W	Foreign matter has been sucked over into the VacuStar W	Rinse thoroughly with diesel-oil-mixture at lowest permissible speed and without pressure or vacuum, afterwards add lubricating oil according to chapter Lubricating oil inspection page 30.	Operator
Power requirement too high	Speed too high	Maintain speed limit	Operator
	End pressure too high	Maintain nominal pressure, actuate / check safety valve	Operator
	Pressure gauge indicates incorrectly	Replace pressure gauge	Operator
	Exhaust silencer clogged	Replace exhaust silencer	Specialised staff
Lack of lubricating oil despite full oil tank	Oil intake strainer in oil tank clogged	Clean oil tank and intake strainer, check oil lines	Operator
Safety valve blows off	Closed valves in the pressure line	Open valves	Operator
	Clogging in pressure system	Eliminate clogging	Operator
	Exhaust silencer clogged	Replace exhaust silencer	Specialised staff
	Closed valves in the suction line	Open valves	Operator

Malfunions

Malfunition:	Possible cause	Corrective action	Execution
Ventilating valve responds	Suction filter clogged	Clean suction filter, if necessary replace filter cartridge	Operator
Compressed air blows off at shaft end and oil is leaking	Seal damaged	Replace radial shaft sealing rings in sealing cover	Specialised staff
Rubber smell (at V-belt drive)	V-belts slip due too insufficient belt tension	Check belt tension, re-tension if necessary	Operator
	End pressure too high	Maintain nominal pressure	Operator
Reversing of V-belts	Insufficient belt tension	Check belt tension, re-tension if necessary	Operator
	Worn V-belts	Put on new V-belts	Operator
	Pulleys are not aligned	Align pulleys	Specialised staff
	Worn V-belt pulleys	Replace pulleys	Specialised staff

9 Spare parts

We recommend stocking a service package as well as a suction filter cartridge.

The service package comprises all wear parts that are required for a normal repair.

Customer Service

In case of queries regarding the product, spare part orders, repairs, replacement machines and dispatch of fitters, please contact our customer service: Phone: +49 (0)7623 71741-31

Spare and wear parts

Model	Service package	Filter cartridge
VacuStar W900	990 000-SP	
VacuStar W1300	990 002-SP	
VacuStar W1600	990 001-SP	
Suction filter 1600 F		432 020-00
Suction filter 1600 G		432 021-00

10 Decommissioning and disposal

A VacuStar W that is no longer usable should not be recycled as complete unit, but disassembled into individual components and recycled according to material types. Non-recyclable materials have to be disposed of in an environmentally compatible manner.

- Prior to decommissioning and disposal of the VacuStar W, it must be completely separated from the surrounding units.
- The disassembly and disposal of the VacuStar W may only be carried out by specialised staff.
- If hazardous or poisonous material were conveyed, the VacuStar W must be decontaminated prior to disposal.
- The VacuStar W has to be disposed of in accordance with the respective country-specific regulations.

Index

A	
Acceptance	9
Action sucking over	29
ATEX	8, 23
C	
Cleaning	
Cooler	28
Suction filter	29
VacuStar W	28
Components, moving	13
Compressed air	13
Compressed air	13
Contact person	7
Copyright protection	7
Customer Service	7
D	
Danger of burns	11
Danger pictogram	11
Danger pictograms	11
Dangers	11
Disposal	38
E	
Explosion protection	11
F	
Function	19
H	
Height wear rotor vanes	31
I	
Improper operation	12
Inspection	
Cell ventilation	25
during operation	22
Lubricating oil	24
Non-return valve	25
prior to initial start-up	21
Safety valve	25
Ventilating valve	25
Instructions	10
Intended use	8
L	
Lengthy standstill	28
Liability	6
Lubricating oils	17
M	
Maintenance	26
Maintenance schedule	26
Maintenance work	28
Malfunction table	34
Malfunctions	32
O	
Occupational safety	11
Operating instructions	4
Operating personnel	10
Operator	9
P	
Packaging	20
Personnel	
Troubleshooting	32
Proper operation	8
Protective equipment	11
Maintenance	26
R	
Recommended oil types	17
Recommissioning	33
S	
Safety	8
Signposting	14
Spare parts	7, 37
Specialised staff	10
Start-up	21
Storage	20
Switching off	23
Symbols in the instructions	5
T	
Technical data	17
Transport	20
W	
Warranty	6, 7
Wear parts	6