

# Operating instructions

## VacuStar L400



Doc-ID: 5028 / BA / EN

Release: Rev. 04 / 28.03.2023

**The operating instructions must be read by the VacuStar L400 operator before start-up!**

# Translation of the original operating manual

© CVS engineering GmbH

Großmattstraße 14  
79618 Rheinfeldern / Germany

Phone: +49 (0)7623 71741-0  
Customer service: +49 (0)7623 71741-0  
E-Mail: [info@cvs-eng.de](mailto:info@cvs-eng.de)  
Internet: [www.cvs-eng.de](http://www.cvs-eng.de)



<b>1</b>	<b>General</b> .....	<b>4</b>
1.1	Information regarding the operating instructions .....	4
1.2	Pictogram explanation .....	5
1.3	Limitation of Liability .....	6
1.4	Copyright protection.....	6
1.5	Spare parts .....	7
1.6	Warranty conditions .....	7
1.7	Customer Service .....	7
<b>2</b>	<b>Safety</b> .....	<b>8</b>
2.1	Intended use .....	8
2.2	Acceptance and monitoring .....	8
2.3	Operator's responsibility .....	8
2.4	Operating personnel .....	9
2.4.1	Requirements .....	9
2.5	Personal protective equipment .....	9
2.6	Occupational safety and special risks .....	10
<b>3</b>	<b>Technical data</b> .....	<b>15</b>
<b>4</b>	<b>Design and function</b> .....	<b>17</b>
4.1	Design.....	17
4.2	Function .....	18
4.3	Control and display elements .....	18
<b>5</b>	<b>Transport and storage</b> .....	<b>19</b>
5.1	Safety notes for transport .....	19
5.2	Transport.....	19
5.3	Storage .....	19
<b>6</b>	<b>Start-up and operation</b> .....	<b>20</b>
6.1	Safety notes .....	20
6.2	Start-up .....	20
6.3	Switching off.....	21
6.4	Inspections to be performed .....	21
<b>7</b>	<b>Maintenance</b> .....	<b>23</b>
7.1	Safety during maintenance work .....	23
7.2	Maintenance schedule .....	23
7.3	Performance of maintenance work .....	25
<b>8</b>	<b>Malfunctions</b> .....	<b>27</b>
8.1	Safety.....	27
8.2	Recommissioning after corrective action .....	27
8.3	Malfunction table.....	28
<b>9</b>	<b>Spare parts</b> .....	<b>30</b>
<b>10</b>	<b>Decommissioning and disposal</b> .....	<b>31</b>
	<b>Index</b> .....	<b>32</b>

## General

# 1 General

## 1.1 Information regarding the operating instructions

These operating instructions provide important information on how to deal with the VacuStar L400. A precondition for safe operation is the observance of all specified safety and handling instructions.

Furthermore, all local accident prevention regulations and general safety regulations valid for the application area of the VacuStar L400 must be observed.

Carefully read the operating instructions before starting any work! It is a product component and must be kept in direct proximity of the VacuStar L400, well accessible to the personnel at all times.

When passing the VacuStar L400 on to third parties, the operating instructions must also be handed over.

## 1.2 Pictogram explanation

### Warning notes

Warning notes are characterised by pictograms in these operating instructions. The warning notes are marked by signal words expressing the extent of the hazard.

It is absolutely essential to observe the notes and to proceed with caution in order to prevent accidents as well as bodily injuries and property damage.



#### **DANGER!**

points to an immediately dangerous situation, which can lead to death or serious injuries if it is not avoided.



#### **WARNING!**

... points to an immediately dangerous situation, which can lead to death or serious injuries if it is not avoided.



#### **CAUTION!**

... points to a potentially dangerous situation, which can lead to minor or light injuries if it is not avoided.



#### **ATTENTION!**

... points to a potentially dangerous situation, which may lead to property damage if it is not avoided.

### Hints and recommendations



#### **NOTE!**

... highlights useful hints and recommendations as well as information for an efficient and trouble-free operation.

## General

### 1.3 Limitation of Liability

All specifications and notes in these operating instructions were compiled with consideration to the valid standards and regulations, the state of the art as well as to our long-standing knowledge and experience.

The manufacturer is not liable for damages caused by:

- Non-observance of the operating instructions
- Improper use
- Deployment of non-trained personnel
- Arbitrary modifications
- Technical changes
- Use of non-approved spare and wear parts.

The actual scope of supply may differ from the explanations and illustrations described in this manual in case of special designs, if additional order options are made use of, or due to latest technical changes.

Incidentally, the responsibilities agreed upon in the delivery contract, the general terms and conditions as well as the manufacturer's conditions of delivery and the statutory provisions valid at the time of contract conclusion shall apply.

### Warranty

The manufacturer guarantees the correct functioning of the applied process technology and the performance parameters identified.

The warranty period commences on the date the VacuStar L400 is delivered to the customer.

Components are exempted from the warranty and from claims for defects as far as wear and tear damage is concerned.

### 1.4 Copyright protection



#### **NOTE!**

*Content details, texts, drawings, pictures and other illustrations are protected by copyright and are subject to industrial property rights. Any improper use shall be liable to prosecution.*

Any type and form of duplication also of extracts as well as the exploitation and/or communication of the contents are not permitted without the manufacturer's written declaration of consent.

## 1.5 Spare parts

**WARNING!****Risk of injury by incorrect spare parts!**

Incorrect or defective spare parts can result in damage, malfunctions or total failure and also impair safety.

Therefore:

- Use only the manufacturer's original spare parts.

Procure spare parts from authorised dealers or directly from the manufacturer. Refer to page 2 for address.

## 1.6 Warranty conditions

Warranty terms see "General Terms of Sale".

## 1.7 Customer Service

Our customer service can be contacted for any technical advice.

Information about the responsible contact person can be retrieved by telephone, fax, E-mail or via the Internet at any time, refer to manufacturer's address on page 2.

## Safety

## 2 Safety

### 2.1 Intended use

The compressor vacuum pump VacuStar L400 is intended exclusively for the compression or suctioning of filtered air.

Only use VacuStar L400 for the intended use.

All specifications in the operating instructions must be strictly adhered to (technical data, operating data, permissible working range), refer to Page 15, chapter 3 in this regard.

All types of claims due to damage arising from improper use are excluded. The operator alone shall be responsible for any damage arising from improper use.

### 2.2 Acceptance and monitoring

The VacuStar L400 is not subject to any acceptance and monitoring obligation.

### 2.3 Operator's responsibility

The VacuStar L400 is used for industrial purposes.

The operator of the VacuStar L400 is therefore subject to the legal obligations concerning occupational safety.

The provisions valid at the place of installation as well as the safety and accident prevention regulations of the Institution for statutory accident insurance and prevention must be observed. The operator must in particular:

- inform himself on the valid industrial safety regulations.
- determine the additional hazards that arise from the special working conditions at the VacuStar L400's place of installation by means of a hazard assessment.
- implement the necessary rules of conduct for operation of the VacuStar L400 at the place of installation by means of user instructions.
- check at regular intervals during the VacuStar L400's entire period of use whether the user instructions correspond to the current state of the body of rules and regulations.
- adapt the operation instructions, if necessary to the new regulations, standards, and operating conditions .
- clearly regulate the responsibilities for installing, operating, maintaining and cleaning the VacuStar L400.
- ensure that all employees working on or with the VacuStar L400 have read and understood the operating instructions. In addition he must at regular intervals train the employees in how to deal with the VacuStar L400 and inform them about potential hazards.



In addition, it is the operator's responsibility to ensure that:

- the machine is always in a technically perfect condition.
- the machine is maintained in accordance with specified maintenance intervals.
- all safety equipment is regularly checked for completeness and correct functioning.

## 2.4 Operating personnel

### 2.4.1 Requirements



**WARNING!**

**Risk of injury in case of inadequate qualification!**

Improper handling can lead to considerable bodily injuries and property damage.

Therefore:

- Have any activities only carried out by the individuals designated for that purpose.

The operating instructions specify the following qualification requirements for the different fields of activity:

- **Instructed persons**  
have been instructed during instructions provided by the operator with regard to the work assigned to them and possible hazards arising from improper conduct.
- **Specialists**  
are due to their technical training, knowledge and experience and their knowledge of the pertinent regulations able to carry out the work assigned to them and to independently recognize potential hazards.

## 2.5 Personal protective equipment

When handling the VacuStar L400, it is necessary to wear personal protective equipment, in order to minimise health hazards.

- Before carrying out any work, properly don the necessary protective equipment such as gloves, safety goggles, etc. and wear during work.

**Safety****2.6 Occupational safety and special risks**

The remaining risks that result from the hazard analysis are specified in the following section.

Observe the safety notes listed here and the warning notes in the other chapters of these instructions to reduce health hazards and to avoid dangerous situations.

**Assembly of the VacuStar L400**

The relevant dangerous spots on the VacuStar L400 are identified by these pictograms:

**DANGER!**  
**General danger pictogram!**

... denotes general dangerous situations for individuals. Non-observance of the safety instructions can result in severe injuries or death. .

**DANGER!**  
**Danger of burns!**

... denotes the presence of a hot surface.

**Hazard notes and occupational safety**

**For your own safety and that of the machine, the following information must be observed and complied with:**

**Improper operation**

**DANGER!**
**Danger due to improper operation!**

- Only use VacuStar L400 in a perfect technical condition. Malfunctions that are relevant for safety have to be promptly eliminated.
- Conversions of the VacuStar L400 are not permissible and can impair safety.
- Never bridge any safety equipment or put it out of operation.
- Any work on the VacuStar L400 and/or on electrical equipment must be carried out by specialised staff.
- Repair and maintenance work may only be carried out when the VacuStar L400 is stationary.  
For this, the VacuStar L400 must be secured against restarting!
- The VacuStar L400 may not be under pressure or in a state of vacuum while work is being carried out on it.  
Close shut-off valve on the vehicle side and vent the pipe between VacuStar L400 and shut-off valve or manually relieve excess pressure at safety valve. Observe pressure gauge!
- The drive's protective equipment may only be removed when the VacuStar L400 is stationary and has to be correctly refitted after completion of work.
- Only dismantle accidental contact protection after VacuStar L400 and pipes have cooled down.
- It is an environmental protection requirement that any liquids arising during maintenance work (e.g. oil) must be collected and disposed of in an environmentally compatible manner.

## Safety

### Moving components

**WARNING!****Risk of injury by moving components!**

Powered rotating components can cause the most serious injuries!

Therefore during operation:

- It is absolutely forbidden for persons to stay in the hazard area or in the immediate vicinity!
- Do not put safety devices and/or functions out of operation and do not render them inoperative or bypass them.
- Never reach into open outlets and inlets or into running equipment.

Before entering the hazard area:

- Switch off power supply and secure against restarting.
- Wait for standstill of lagging components.
- Wait for automatic dissipation and/or discharge of residual energies (compressed air).

### Compressed air

**WARNING!****Risk of injury due to compressed air!**

Pneumatic energies can cause the most serious injuries.

In the case of damage to individual components, air can be discharged under high pressure and injure e.g. the eyes. Therefore:

- Before starting any work, first depressurise pressurised components. Pay attention to accumulators. Accumulator pressure must also be completely relieved.

### Signposting

**WARNING!****Risk of injury by illegible pictograms!**

Labels and signs can become dirty or unrecognisable in the course of time.

Therefore:

- Always keep safety, warning and operating instructions in a well legible condition.
- Immediately replace damaged or obliterated signs or labels.

**Improper transport**

**Danger!**  
**Danger by falling down or tilting of the VacuStar L400!**

The weight of the VacuStar L400 may injure a person and cause serious bruising!

Therefore:

- Depending on the dead weight and size of the VacuStar L400, use a pallet on which the VacuStar L400 can be moved by means of a fork lift.
- For lifting the VacuStar L400, use suitable lifting gear (slings, etc.) that is designed for the weight of the VacuStar L400.
- When putting the slings in position, take care to avoid putting stress on individual components.
- Only use the provided attachment points with eye bolts.

**Start-up and operation**

**WARNING!**  
**Risk of injury due to improper start-up and operation**

Improper start-up and operation can lead to serious bodily injuries or property damage. Therefore:

- Have all work during initial operation exclusively performed by the manufacturer's employees or by his authorised representatives or by trained personnel.
- Start-up and operation may only be performed by adequately qualified personnel that has been authorised and instructed by the operator.
- Before the start of any work, ensure that all covers and protective devices are correctly installed and function correctly.
- Never override any protective equipment during operation.
- Pay attention to tidiness and cleanliness in the working area! Loosely stacked or scattered components and tools are accident sources.

## Safety

### Electrical system



**DANGER!**  
**Mortal danger due to electric current!**

There is mortal danger in case of contact with live components.

Activated electrically driven components can start to move uncontrolled and cause severest injuries.

Therefore:

- Switch off the electric power supply before commencing any work and secure against restarting.
- Work on the electrical system, on individual electrical components and on the connections may only be carried out by electrical specialists.

### Maintenance and troubleshooting



**WARNING!**  
**Risk of injury due to improper maintenance and troubleshooting!**

Improper maintenance and troubleshooting can lead to serious bodily injuries or property damage.

Therefore:

- Maintenance work and troubleshooting work may only be carried out by sufficiently qualified and instructed personnel.
- Protect VacuStar L400 from being restarted, switch off drives!
- Before starting any work, provide for sufficient space and freedom of movement during assembly.
- Pay attention to tidiness and cleanliness in the assembly area! Loosely stacked or scattered components and tools are accident sources.

If components must be replaced:

- Pay attention to correct installation of spare parts.
- Properly reassemble all fastening elements.
- Observe screw tightening torques.
- Before restarting, ensure that all covers and protective devices are correctly installed and function correctly.
- After completion of maintenance work and troubleshooting, check correct functioning of safety equipment.

### 3 Technical data

General data	Unit	VacuStar L400
Rated speed / Speed range	[1/min]	1500 / 1000 to 1500
Suction temperature	[°C]	-20...+40
Geodetic height	[m]	0...1000
Content of oil container	[Litres]	4.6
Lubricating oil consumption	[ml/h]	85
Weight VacuStar L400 without accessories	[kg]	76

Tab. 1: General data

Operating data during compressor vacuum pump operation at rated speed	Unit	VacuStar L400
Vacuum without cell venting / with cell venting <sup>1)</sup>	[mbar]	200 / 100
Final overpressure at the pressure flange <sup>2)</sup>	[bar]	0 to 0.5
Intake volume flow at 400 / 1000 mbar	[m <sup>3</sup> /h]	320 / 345
Power requirement at 400 mbar / 0.5 bar excess pressure	[kW]	7.4 / 10
Sound pressure level (at 7 m distance) at 200 mbar / 0.5 bar excess pressure	[dB]	70 / 78
Weight VacuStar L400 with a four-way switching valve	[kg]	85

1) Final excess pressure at the pressure flange = 0 bar, suction and ambient temperature = 20 °C

2) Intake pressure at the suction flange = 1 bar, suction and ambient temperature = 20 °C

Tab. 2: Operating data VacuStar L400 during compressor vacuum pump operation at rated speed

Operating data during compressor operation at rated speed	Unit	VacuStar L400
Intake pressure	[mbar]	1000
Final overpressure at the pressure flange <sup>1) 3)</sup>	[bar]	0 to 2.0
Intake pressure at 0 / 2.0 bar excess pressure <sup>2)</sup>	[m <sup>3</sup> /h]	345 / 305
Power requirement at 0 / 2.0 bar excess pressure <sup>2)</sup>	[kW]	8 / 19.0
Sound pressure level (at 7 m distance) at 2.0 bar excess pressure <sup>2)</sup>	[dB]	77
Weight VacuStar L400 with mounting flange for suction and pressure line	[kg]	79

1) Suction and ambient temperature = 20 °C

2) at rated speed

3) Protection via a safety valve

Tab. 3: Operating data VacuStar L400 during compressor operation at rated speed

## Technical data

### Lubricating oil

The use of multigrade oils will damage the VacuStar L400. In that case, the warranty on the part of CVS Engineering GmbH shall cease.

Only single grade oils with the following specification are permitted for operation:

Specification	Value
API	CF/CF4 or higher
ACEA	E2 or higher
Viscosity:	Suction temperature > 10 °C: SAE 40 Suction temperature < 10 °C: SAE 30

Tab. 4: Lubricating oils

### Lubricating oil types

Recommended oil types

Brand	Suction temp. > 10 °C	Suction temp. < 10 °C
CVS	CVS Lube 4000	CVS Lube 3000

Other oil types on request.

Tab. 5: Lubricating oil types



#### ATTENTION!

Do not use any synthetic lubricants!



## 4 Design and function

### 4.1 Design

A:

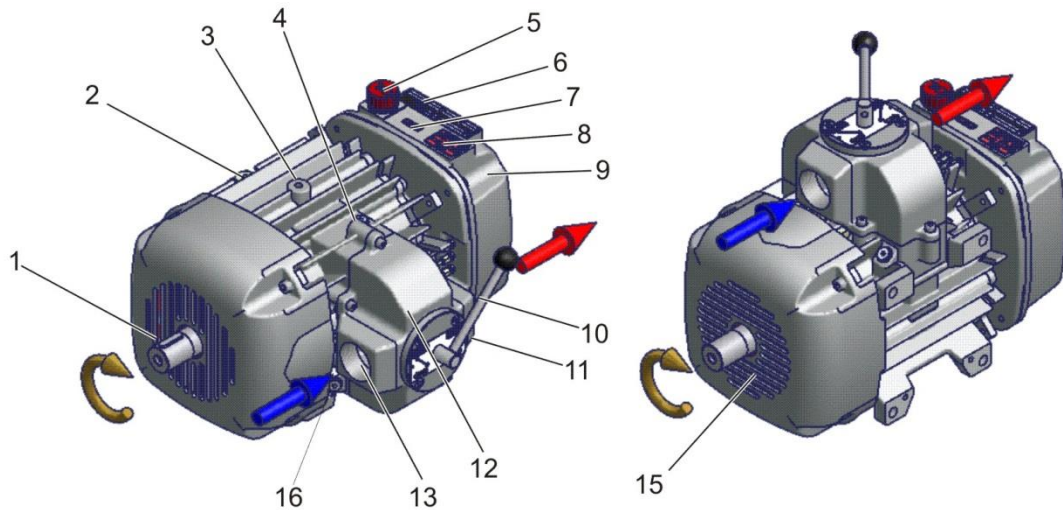

B:

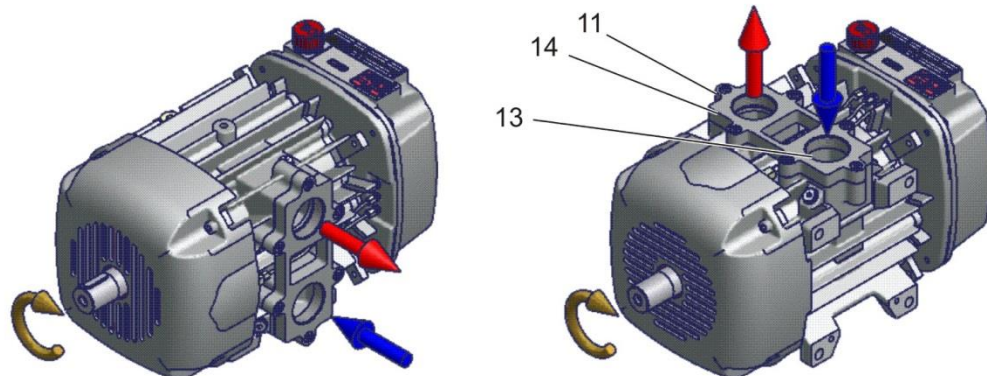

Fig. 1: Design VacuStar L400 with and without a four-way switching valve

A: Compressor vacuum pump operation with four-way switching valve

The air feed direction (suction or pressure) is selected by the position of the switching lever.

B: Compressor or vacuum pump operation with mounting flange for suction and pressure line

- |   |  |    |  |
|---|--|----|--|
| 1 | Drive shaft                              | 10 | Switching lever  |
| 2 | Cell ventilation connection              | 11 | Pressure connection<br>(for illustrated lever setting) |
| 3 | Thread for eye bolt                      | 12 | Four-way switching valve                               |
| 4 | Temperature and pressure measuring point | 13 | Suction connection<br>(for illustrated lever setting)  |
| 5 | Oil filling                              | 14 | Mounting flange for lines                              |
| 6 | Rating plate of VacuStar L400            | 15 | Suction opening for cooling air                        |
| 7 | Rotation arrow                           | 16 | Connection for measuring control line                  |
| 8 | Rating plate oil                         |    |  |
| 9 | Oil reservoir                            |    |  |

## Design and function

### 4.2 Function

#### Functional principle

Sliding vane compressor vacuum pumps work according to the displacement principle.

Due to the rotor's eccentric arrangement inside the casing, limited, crescent-shaped working chambers are created by means of the rotor vanes, which are enlarged or reduced with every turn of the rotor.

Cleaned air is drawn in via the suction connection (pos. 13) and reaches the pressure line after being compressed via the pressure connection (pos. 11).

#### Lubrication

The VacuStar L400 is lubricated by means of an oil pump. Oil is pumped from the oil reservoir via the oil lines to the VacuStar L400's lubricating points.

#### Cooling

The VacuStar L400 is air-cooled. Heat removal is performed by casing ribs on the lid and casing surface with targeted cooling air guidance, via a ventilation wheel on the drive shaft.

#### Drive

The VacuStar L400 can be powered via:

- Articulated shaft
- V-belt
- Flexible coupling

Details about the drives and their design can be found in the separate mounting instructions for the VacuStar L400.

### 4.3 Control and display elements

Depending on the installation situation, different display elements such as pressure gauge, temperature gauge and negative pressure display are mounted.

## 5 Transport and storage

### 5.1 Safety notes for transport

See chapter 2.6.

### 5.2 Transport

The VacuStar L400 fastened on a pallet must be transported by means of a fork lift or suitable lifting gear. The lifting gear must be designed for the weight of the VacuStar L400.

#### **For future transports:**

- Seal all open connections with protective caps (prevents penetration of dirt and water)
- Secure against vibrations
- Securely fasten the VacuStar L400 prior to transport (e.g. screw it onto a pallet)
- Transport and put down the VacuStar L400 with a fork lift or secure with straps and lift with suitable lifting gear.

### 5.3 Storage

#### **Storage of packages**

Store packages under the following conditions:

- Do not store outdoors.
- Store dry and dust free.
- Do not expose to aggressive media.
- Protect against solar irradiation.
- Avoid mechanical vibrations.
- Storage temperature: -10 to +60 °C
- Relative humidity: max. 95%, non-condensing
- If storage lasts longer than 3 months, regularly check the general condition of all parts and of the packaging.
- To keep moisture away from the VacuStar L400's workspace, bags with desiccant must be placed into the inlets and outlets. These must be removed before start-up.

## Start-up and operation

# 6 Start-up and operation

## 6.1 Safety notes

See chapter 2.6.

## 6.2 Start-up

### Inspection prior to initial start-up

Top up **lubricating oil** according to lubricating oil schedule. Oil level in the oil supply tank at least to the middle of the oil sight glass.

### Start-up

- Open present shut-off devices
- Select with VacuStar L400 during compressor vacuum pump operation at suction or pressure operation with four-way switching valve.  
Attention: Switching valve must only be operated in the two end positions. Intermediate positions are not permitted.
- Start the VacuStar L400 drive.
- Adjust speed.
- Check operating data

### Inspections during operation

The following inspections have to be carried out during operation:

- Prior to every start-up and during operation, the oil level must be checked and topped up if necessary.
- Open shut-off devices. Always turn the four-way cock until it hits the stop, intermediate positions are not permitted.
- Switch on drive and check whether pressure or vacuum are created.
- Pay attention to abnormal noises and leaks during operation. If necessary, switch off VacuStar L400.
- Drain condensate at the condensate and safety traps. Vessel may not be in a state of vacuum when condensate is drained.

Checking the operating data:

- The speed must range between 1000...1500 min<sup>-1</sup>.
- Check positive working pressure at the pressure gauge (permissible pressure refer to rating plate).
- Check the operating vacuum at the vacuum meter (permissible vacuum refer to rating plate).
- The compression end temperature at 20 °C suction temperature may not exceed the following values:  
150 °C at 400 mbar operating vacuum  
120 °C at 0.5 mbar excess pressure

### 6.3 Switching off

Switch off the VacuStar L400 as follows:

- Switch off drive for the VacuStar L400.
- Close the shut-off valves (if installed)
- Drain the safety tank. Tank may not be under pressure then.

### 6.4 Inspections to be performed

#### Lubricating oil inspection

*Only lubricating oils pursuant to the lubricants specifications lubricating oil schedule (Tab. 4, Other oil types on request.*

Tab. 5

Check oil level at the inspection glass. Oil level in the oil supply tank at least to the middle of the oil sight glass. The oil level may not drop below the bottom mark on the oil inspection glass.

#### Non-return valve inspection

The non-return valve is maintenance-free, but is subject to wear like all other moving parts. We recommend a visual inspection every 3 months. In this connection, the non-return valve must be dismantled, cleaned, freed of deposits and checked for freedom of motion.

#### Safety valve inspection

**The safety valve is no regulating device!  
The operational capability must be checked on start-up and later at weekly intervals.**

The safety valve must be secured against misadjustment. Blocking or manipulating the safety valve can have penal consequences if it gives rise to an accident. Any warranty claims shall also be forfeited in such a case.

The nominal opening pressure may not exceed the maximum permissible final overpressure (refer to rating plate) or the permissible system pressure, provided the latter is lower.

Functional testing is carried out by actuating the manual ventilation with the VacuStar L400 running.

#### Inspection of the ventilating valve

As a matter of principle, a ventilating valve must be installed as safety element on the VacuStar L400's suction side. When the set vacuum is reached, the ventilating valve opens and admits atmospheric auxiliary air into the system. The operational capability must be checked weekly with the aid of a vacuum meter at the VacuStar L400's inlet. In case of systems without cell ventilation, the vacuum may not drop below the permissible value of 200 mbar.

In case of systems with cell ventilation, the vacuum may not drop below the permissible value of 100 mbar.



## 7 Maintenance

### 7.1 Safety during maintenance work

See chapter 2.6 "Occupational safety and special risks".

#### Personal protective equipment

The following must be worn during all maintenance work:

- Safety working clothing
- Protective gloves
- Safety shoes
- Safety goggles

#### Environmental protection

Observe the following information with regard to environmental protection during maintenance:

- Remove emerging, used or excessive grease at all lubricating points that are manually supplied with lubricant and dispose of in accordance with valid local regulations.
- Collect exchanged oil in suitable containers and dispose of in accordance with valid local regulations.

### 7.2 Maintenance schedule

The following describes the maintenance work that is necessary for an optimum, trouble-free operation. Maintenance intervals must be observed.

If increased wear of individual components or functional groups is determined during regular inspections, the operator has to reduce the required maintenance intervals on the basis of the actual signs of wear.

Changes compared to normal operation (increased power consumption, temperatures, vibrations, noises, etc. or response of monitoring systems) lead to the assumption that the functions are impaired. These then have to be subjected to an inspection by specialised staff.

In case of queries regarding the maintenance work and intervals: contact the manufacturer (service address → page 2).

For maintenance schedule refer to next page.

## Maintenance

### Maintenance schedule

Interval	Maintenance work	To be carried out by
Every 15 minutes	Check operating speed	Operator
	Check operating pressure / vacuum	
	Check air outlet temperature	
Daily	Check condensate	Operator
	Check safety trap	
	Check silencer	
	Check oil level and top up with fresh oil if necessary	
Weekly	Check safety valve	Operator
	Check ventilating valve	
	Clean VacuStar L400	
	Clean vacuum filter	
	Check V-belt, V-belt tension and re-tension if necessary	
Monthly	Clean cell ventilation filter, replace if damaged	Operator
	Clean oil tank	
	Check fastening screws and tighten if necessary	
quarterly	Check shaft sealing rings for tightness (no oil may leak from them)	Specialised staff
	Check rotor vane wear (replace vane at more than 5 mm)	
Half-yearly	Check cell ventilation valve	Specialised staff
	Check non-return valve of VacuStar L400	Specialised staff
5,000 oh / 3 years	Replace shaft sealing rings	Specialised staff
10,000 oh / 5 years	Replace bearings	Specialised staff

Tab. 6: Maintenance schedule



### 7.3 Performance of maintenance work

#### Cleaning the VacuStar L400

Carrying out cleaning work:

1. Switch off system and secure against restarting.
2. Remove soiling appropriately. Observe the following:
  - Do not use aggressive cleaning agents.
  - Pay attention during cleaning that no water gets into the compression chamber.
  - Exercise special caution when cleaning with high-pressure cleaning systems.
  - Absorb oil deposits with oil-absorbing materials (e.g. sawdust).
  - After cleaning work, check that all previously opened covers and safety equipment are correctly installed and function correctly.
  - After wet cleaning, warm up the VacuStar W for a few minutes.

#### Cooling of the VacuStar L400

To warrant best cooling, the protective grid apertures must be free of deposits.

#### Suction air filter

The contamination state is usually indicated by a maintenance display. If maintenance is required, open filter casing and replace filter cartridge.

#### Action after lengthy standstill

If the standstill of the VacuStar L400 installed inside the vehicle lasts for more than a month, we recommend putting the VacuStar L400 into operation once a month for 15 minutes.

## Maintenance

### Action after sucking over of foreign matter

If foreign matter has been sucked over into the VacuStar L400, proceed as follows:

- Allow VacuStar L400 to cool down.
- Unscrew the locking screw in the inlet (fig. 1, pos. 16)
- Open vehicle box to allow the VacuStar L400 to be run without vacuum or pressure build-up.
- Switch on VacuStar L400 and allow approx. 0.5...1 l of a diesel-oil-mixture (1:1 mixing ratio) to be sucked into the VacuStar L400 through the hole in the inlet at approx. 1000 min<sup>-1</sup>.
- Afterwards, allow another 0.2 - 0.5 l clean oil to be sucked in via the inlet.
- Completely remove this diesel-oil-mixture from the VacuStar L400 and do not allow to collect in the downstream silencer - fire hazard!
- Switch off VacuStar L400 and re-attach locking screw. Perform a lubricating oil inspection pursuant to chapter 6.4 before the VacuStar L400 is restarted.

## 8 Malffunctions

This chapter describes possible causes of malffunctions and troubleshooting tasks.

Reduce the maintenance intervals if similar malffunctions occur repeatedly due to above-average intensive use so intervals correspond to the actual load.

Contact the manufacturer in case of malffunctions that cannot be repaired with the aid of the following information (→ p. 2)!

### 8.1 Safety

See chapter 2.6 "Occupational safety and special risks".

#### Personnel

- The trouble shooting work described at this point can be carried out by the operator, unless otherwise indicated.
- Some work may only be carried out by specially trained specialised staff or exclusively by the manufacturer himself. This is specifically pointed out in the description of the individual malffunctions.
- Only electrical specialists may carry out work on the electrical system.
- Components and parts may only be replaced by specialised staff.

#### Personal protective equipment

See chapter 2.5.

#### Environmental protection

See chapter 7.1.

#### Conduct in the case of malffunctions

The following basically applies:

1. Immediately trigger an EMERGENCY-STOP in case of malffunctions constituting an immediate danger for individuals or material assets.
2. Switch of all power supplies and secure against restarting.
3. Inform person in charge at the place of installation.
4. Depending on the type of malfunction, have the cause determined and eliminated by responsible and authorised specialised personnel.

### 8.2 Recommissioning after corrective action

After corrective action or trouble shooting:

1. Reset emergency stops.
2. Acknowledge error message or malfunction at the control system.
3. Ensure that nobody is staying in the hazard area.
4. Start in accordance with the instructions in chapter „start-up“.

## Malfuncions

### 8.3 Malfunction table

Malfunction:	Possible cause	Corrective action	Execution
<b>VacuStar L400's delivery rate decreases</b>	Vacuum filter soiled	Clean vacuum filter	Operator
	Leaky suction line / fittings	Look for leaky spots and eliminate leak	Specialised staff
	Speed too low	Adjust speed	Operator
	Wear of rotor vanes, possibly caused by dirt or liquids that have gotten into the VacuStar L400 (sucking over of foreign matter)	Replace rotor vane, remove dirt and have VacuStar L400 overhauled at an authorised workshop	Specialised staff
<b>Abnormal noise emission</b>	VacuStar L400 is badly aligned.	Align the VacuStar L400 precisely.	Specialised staff
	Bearing defective	Replace bearing (or have it replaced)	Specialised staff
	Lack of lubricating oil	Top up oil, clean oil reservoir and suction filter	Operator
	Unsuitable lubricating oil	Fill in oil according to lubrication schedule	Operator
	Rotor vanes are jammed	Check rotor vanes	Specialised staff
	Casing bore shows grooves or corrugations due to the aspiration of dirt	Have casing bore re-turned and honed at an authorised workshop. In case of heavily soiled intake air, install fine filter	Specialised staff
	Wrong speed	Maintain speed range	Operator
	Changed pressure	Maintain nominal pressure	Operator
	Changed vacuum	Maintain nominal vacuum, check exhaust system and clean if necessary	Operator
	Non-return valve rattles	Check non-return valve	Specialised staff
	Foreign bodies in the VacuStar L400	Remove foreign matter. Flush out the VacuStar L400.	Specialised staff
	Slide breakage	Switch off the VacuStar L400 at once and repair it.	Specialised staff
<b>Compressed air temperature too high</b>	End pressure too high	Maintain nominal pressure	Operator
	Exhaust silencer clogged	Replace exhaust silencer	Specialised staff
	Four way cock in wrong position	Correctly adjust four way cock	Operator
	Non-return valve is stuck	Check non-return valve and clean if necessary	Specialised staff
	Vacuum filter clogged	Clean vacuum filter	Operator
	Vacuum too high	Maintain nominal vacuum	Operator

**Malfunctions**

Malfunction:	Possible cause	Corrective action	Execution
<b>Operating pressure or operating vacuum is not obtained</b>	Pressure gauge or vacuum meter do not indicate correctly	Replace pressure gauge or vacuum meter	Specialised staff
	V-belts are slipping	Check V-belt tension and re-tension if necessary	Operator
	Four way cock in wrong position	Correctly adjust four way cock	Operator
	Condensate drain cock open	Close condensate drain cock	Operator
<b>Silt or liquid has gotten into the VacuStar L400</b>	Foreign matter has been sucked over into the VacuStar L400	Rinse thoroughly with diesel-oil-mixture at lowest permissible speed and without pressure or vacuum, afterwards add lubricating oil according to chapter Lubricating oil inspection page 21.	Operator
<b>Power requirement too high</b>	Speed too high	Maintain speed limit	Operator
	End pressure too high	Maintain nominal pressure, actuate / check safety valve	Operator
	Pressure gauge indicates incorrectly	Replace pressure gauge	Operator
	Exhaust silencer clogged	Replace exhaust silencer	Specialised staff
<b>Lack of lubricating oil despite full oil tank</b>	Oil intake strainer in oil tank clogged	Clean oil tank and intake strainer, check oil lines	Operator
<b>Safety valve blows off</b>	Closed valves in the pressure line	Open valves	Operator
	Clogging in pressure system	Eliminate clogging	Operator
	Exhaust silencer clogged	Replace exhaust silencer	Specialised staff
<b>Ventilating valve responds</b>	Closed valves in the suction line	Open valves	Operator
	Suction filter clogged	Clean suction filter, if necessary replace filter cartridge	Operator
<b>Compressed air blows off at shaft end and oil is leaking</b>	Seal damaged	Replace radial shaft sealing rings in sealing cover	Specialised staff
<b>Rubber smell (at V-belt drive)</b>	V-belts slip due too insufficient belt tension	Check belt tension, re-tension if necessary	Operator
	End pressure too high	Maintain nominal pressure	Operator
<b>Reversing of V-belts</b>	Insufficient belt tension	Check belt tension, re-tension if necessary	Operator
	Worn V-belts	Put on new V-belts	Operator
	Pulleys are not aligned	Align pulleys	Specialised staff
	Worn V-belt pulleys	Replace pulleys	Specialised staff

Tab. 7: Malfunction table

## Spare parts

### 9 Spare parts

We recommend stocking a service package as well as a suction filter cartridge.

The service package comprises all wear parts that are required for a normal repair.

#### **Customer Service**

In case of queries regarding the product, spare part orders, repairs, replacement machines and dispatch of fitters, please contact our customer service: Phone: +49 (0)7623 71741-0

#### **Spare and wear parts**

Service package	990 008-SP
Filter cartridge to cell venting	432 151-00
Filter cartridge to suction air filter	432 161-00

## 10 Decommissioning and disposal

A VacuStar L400 that is no longer usable should not be recycled as complete unit, but disassembled into individual components and recycled according to material types. Non-recyclable materials have to be disposed of in an environmentally compatible manner.

- Prior to decommissioning and disposal of the VacuStar L400, it must be completely separated from the surrounding units.
- The disassembly and disposal of the VacuStar L400 may only be carried out by specialised staff.
- If hazardous or poisonous material were conveyed, the VacuStar L400 must be decontaminated prior to disposal.
- The VacuStar L400 has to be disposed of in accordance with the respective country-specific regulations.

## Index

### Index

<b>A</b>	
Acceptance .....	8
Action sucking over .....	26
<b>C</b>	
Cleaning	
VacuStar L400 .....	25
Components, moving .....	12
Compressed air .....	12
Contact person .....	7
Cooling .....	18, 25
Copyright protection .....	6
Customer Service .....	7
<b>D</b>	
Danger of burns .....	10
Danger pictogram .....	10
Danger pictograms .....	10
Dangers .....	10
Design .....	17
Display elements .....	18
Disposal .....	32
Drive .....	18
<b>E</b>	
Environmental protection .....	23, 27
<b>F</b>	
Function .....	18
<b>I</b>	
Improper operation .....	11
Inspection	
30/38 rotor vane .....	22
during operation .....	20
Lubricating oil .....	21
Non-return valve .....	21
prior to initial start-up .....	20
Safety valve .....	21
Ventilating valve .....	21, 22
Instructions .....	9
Intended use .....	8
<b>L</b>	
Lengthy standstill .....	25
Liability .....	6
Lubricating oil .....	16
Lubricating oil types .....	16
Lubrication .....	18
<b>M</b>	
Maintenance .....	23
Maintenance .....	14
Maintenance schedule .....	23
Maintenance work .....	25
Malfunction table .....	28
Malfunctions .....	27
<b>O</b>	
Occupational safety .....	10
Operating elements .....	18
Operating instructions .....	4
Operating personnel .....	9
Operation .....	13, 20
Operator .....	8
<b>P</b>	
Personnel	
Trouble shooting .....	27
Protective equipment .....	9, 23, 27
<b>R</b>	
Recommissioning .....	27
<b>S</b>	
Safety .....	8, 27
Safety notes .....	19, 20, 23
Signposting .....	12
Spare parts .....	7, 31
Specialists .....	9
Start-up .....	13, 20
Storage .....	19
Suction air filter .....	25
Switching off .....	21
Symbols in the instructions .....	5



<b>T</b>		
Technical data .....	15	
Transport .....	13, 19	
		<b>Trouble shooting</b> .....
		14
		<b>W</b>
		Warranty .....
		6, 7